



AN OSRAM BUSINESS

A.LEDA WASH K10

A.LEDA WASH K20

C61405

C61410

INSTRUCTION MANUAL

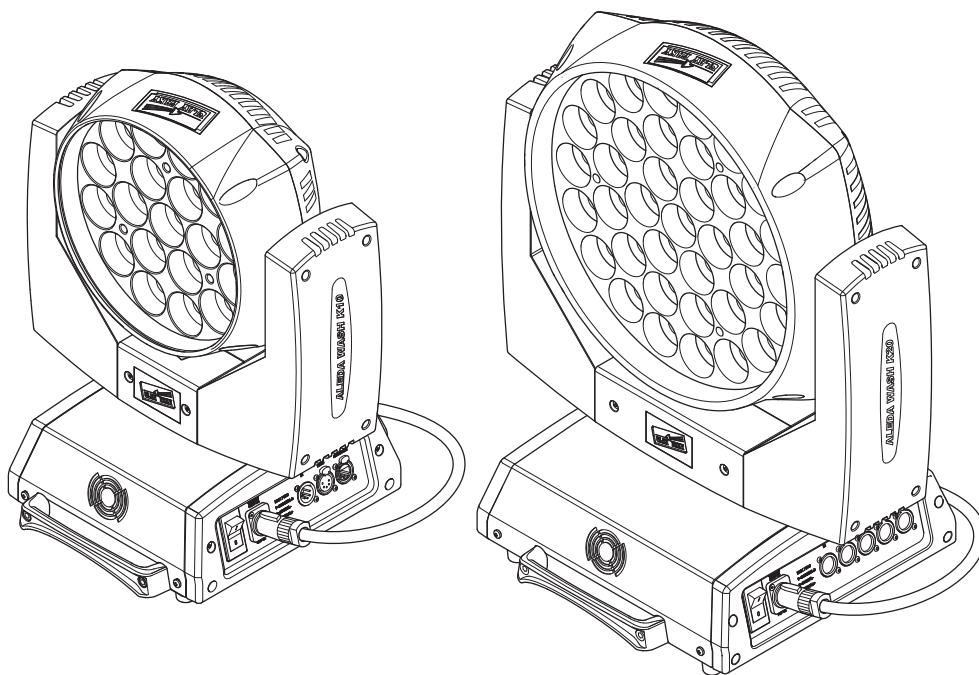

INDEX	
Page	Contents
2	Safety Information
3	Unpacking and preparation
4	Installation and start-up
5	Control panel
7	Menu setting
15	Maintenance
19	Technical information
19	Cause and solution of problems

Congratulations on choosing a Clay Paky product!

We thank you for your custom.

Please note that this product, as all the others in the rich Clay Paky range, has been designed and made with total quality to ensure excellent performance and best meet your expectations and requirements.

Carefully read this instruction manual in its entirety and keep it safe for future reference. It is essential to know the information and comply with the instructions given in this manual to ensure the fitting is installed, used and serviced correctly and safely.

CLAY PAKY S.p.A. disclaims all liability for damage to the fitting or to other property or persons deriving from installation, use and maintenance that have not been carried out in conformity with this instruction manual, which must always accompany the fitting.

CLAY PAKY S.p.A. reserves the right to modify the characteristics stated in this instruction manual at any time and without prior notice.

SAFETY INFORMATION

EN

SAFETY INFORMATION

IMPORTANT: Clay Paky recommends you carefully read and keep the safety information on this product, also available in digital format at the following link:

<http://www.claypaky.it/en>

Ref: [FIS00P – Safety Information A.leda Wash series]

IT

INFORMAZIONI DI SICUREZZA

IMPORTANTE: Clay Paky raccomanda di leggere accuratamente e conservare le informazioni di sicurezza relative a questo prodotto, sempre reperibili in versione digitale al seguente link:

<http://www.claypaky.it/en/download>

Rif: [FIS00P – Safety Information A.leda Wash series]

DE

INFORMATIONEN ZUR SICHERHEIT

WICHTIG: Clay Paky empfiehlt, die Sicherheitsinformationen bezüglich dieses Produkts genau zu lesen und aufzubewahren. Sie sind in Digitalversion immer unter folgendem Link auffindbar:

<http://www.claypaky.it/en/download>

Ref: [FIS00P – Safety Information A.leda Wash series]

ES

INFORMACIONES DE SEGURIDAD

IMPORTANTE: Clay Paky recomienda leer detenidamente y conservar la información de seguridad relativa a este producto. Además, está disponible una versión digital de la misma en el siguiente enlace:

<http://www.claypaky.it/en/download>

Ref: [FIS00P – Safety Information A.leda Wash series]

FR

CONSIGNES DE SÉCURITÉ

IMPORTANT: Clay Paky recommande de lire attentivement et de conserver les informations de sécurité relatives à ce produit, disponibles en version digitale au lien suivant:

<http://www.claypaky.it/en/download>

Réf. : [FIS00P – Safety Information A.leda Wash series]

RU

ИНСТРУКЦИЮ ПО ТЕХНИКЕ БЕЗОПАСНОСТИ

ВАЖНО: Clay Paky рекомендует внимательно прочитать и сохранить инструкцию по технике безопасности данного изделия, которая всегда доступна в электронном формате по следующей ссылке:

<http://www.claypaky.it/en/download>

Наименование: [FIS00P – Safety Information A.leda Wash series]

UNPACKING AND PREPARATION



Packing contents - Fig. 1

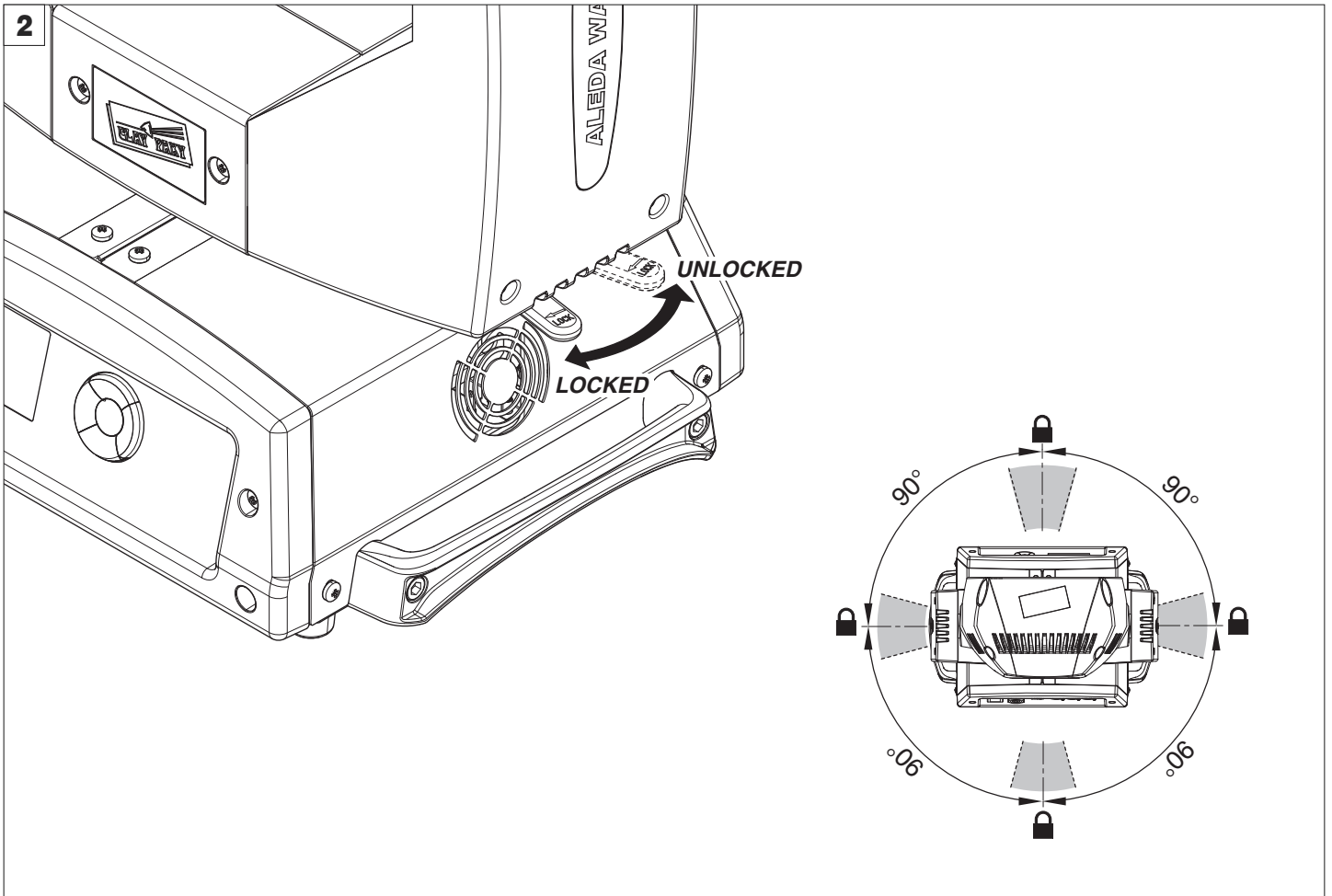

PAN Mechanism Lock and Release (every 90°) - Fig. 2

INSTALLATION AND START-UP

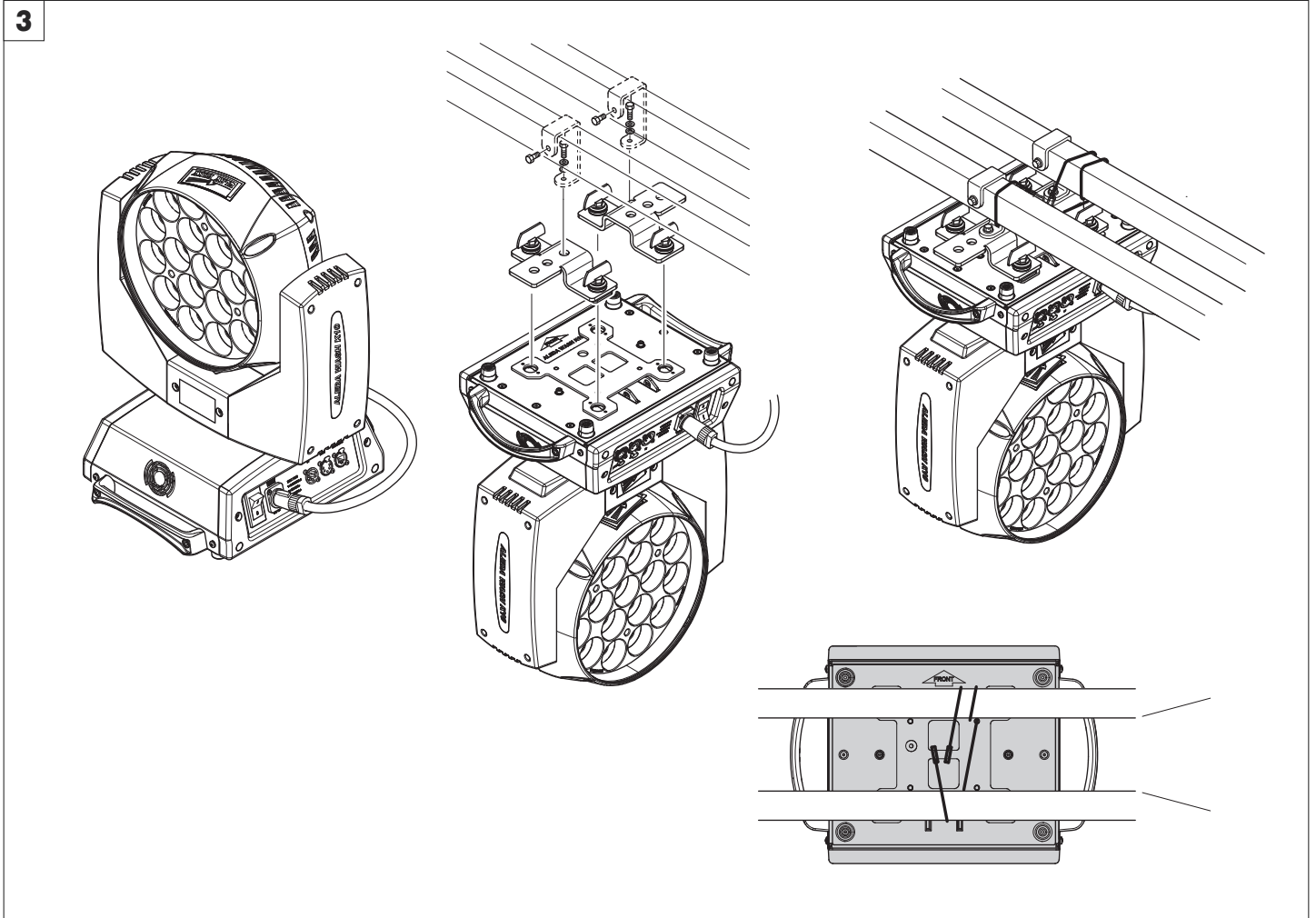

Installing the projector - Fig. 3

The projector can be installed on the floor resting on special rubber feet, on a truss or on the ceiling or wall.

WARNING: with the exception of when the projector is positioned on the floor, the safety cable must be fitted. (Cod. 105041/003 available on request). This must be securely fixed to the support structure of the projector and then connected to the fixing point at the centre of the base.

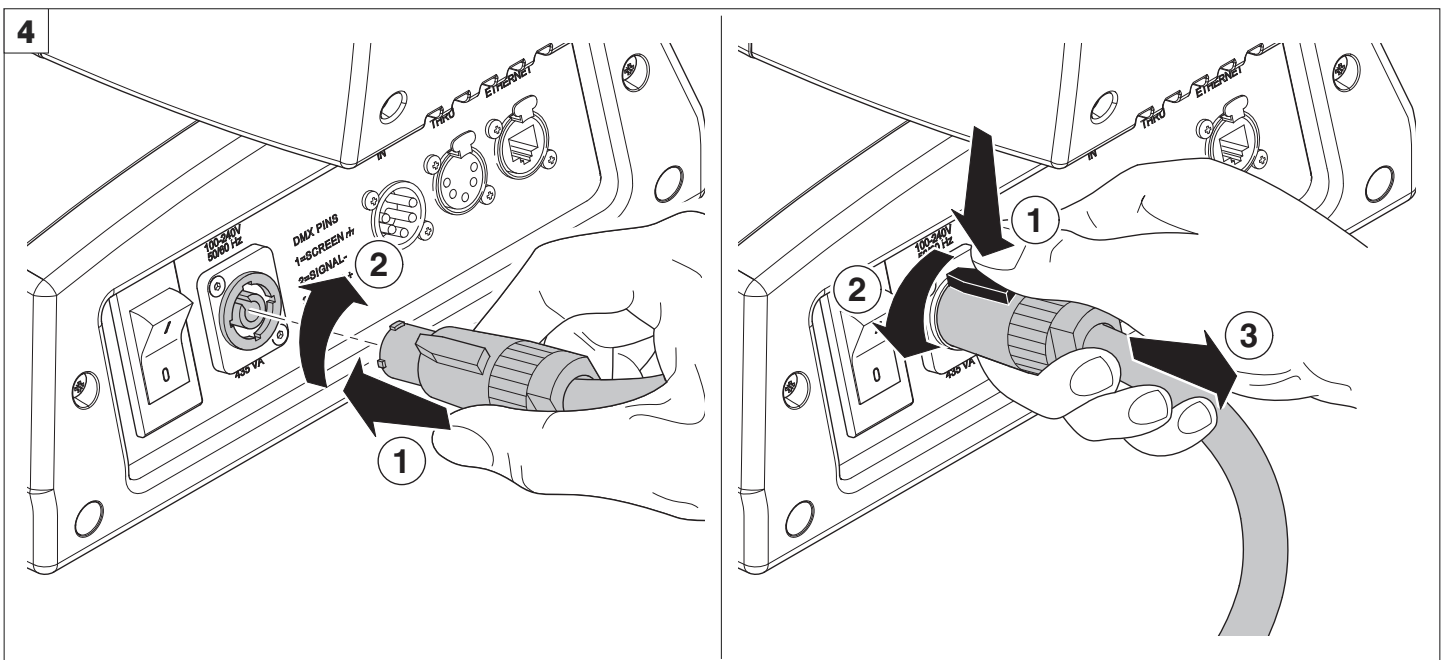

Connecting and disconnecting power cable - Fig. 4

CONTROL PANEL

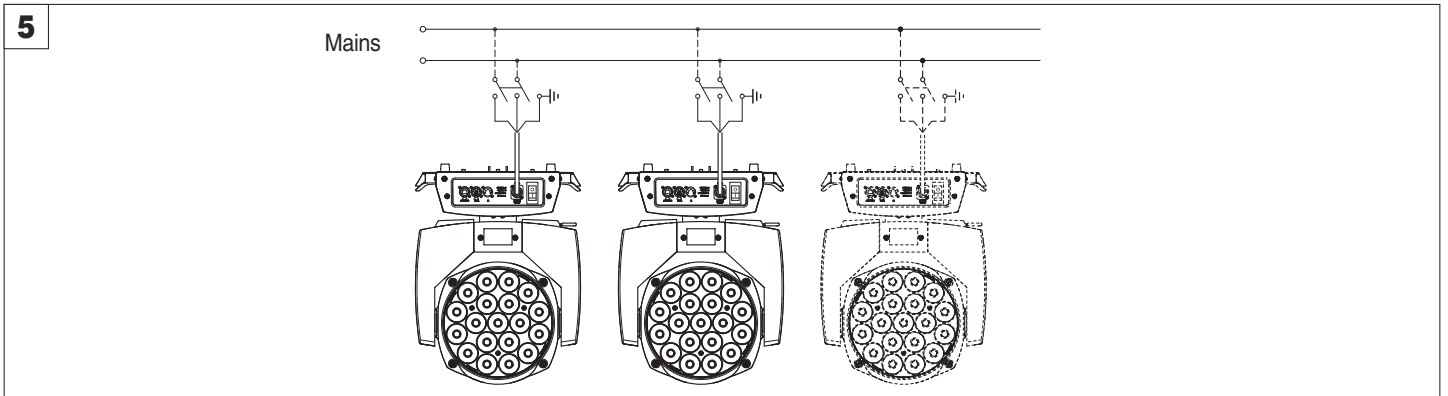

Connecting to the mains supply - Fig. 5

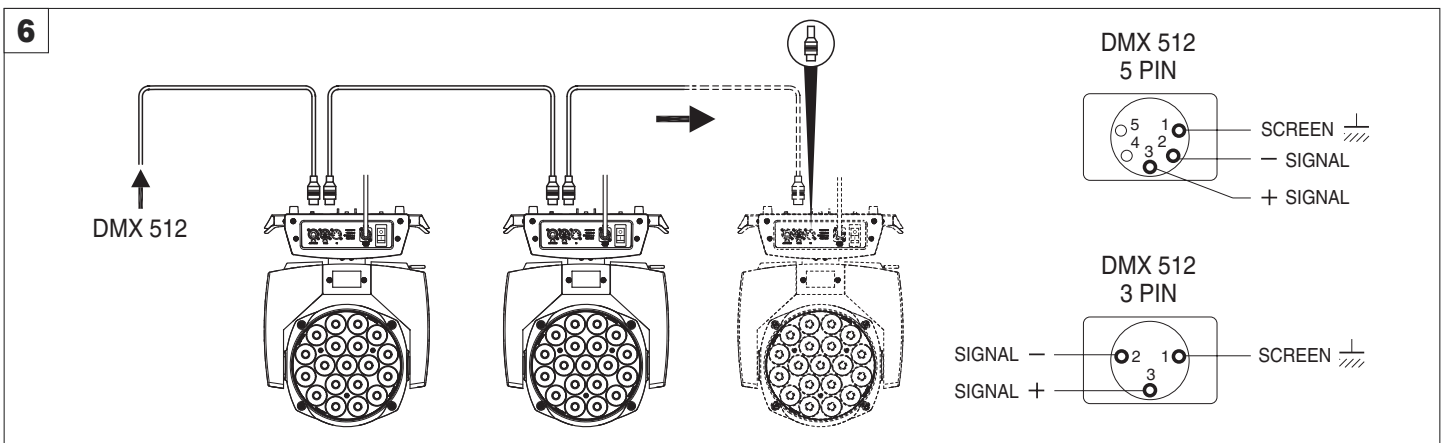

Connecting to the control signal line (DMX) - Fig. 6

Use a cable conforming to specifications EIA RS-485: 2-pole twisted, shielded, 120Ohm characteristic impedance, 22-24 AWG, low capacity. Do not use microphone cable or other cable with characteristics differing from those specified. The end connections must be made using XLR type 3 or 5-pin male/female connectors. A terminating plug must be inserted into the last projector with a resistance of 120Ohm (minimum 1/4 W) between terminals 2 and 3.

IMPORTANT: The wires must not make contact with each other or with the metal casing of the connectors. The casing itself must be connected to the shield braid and to pin 1 of the connectors.

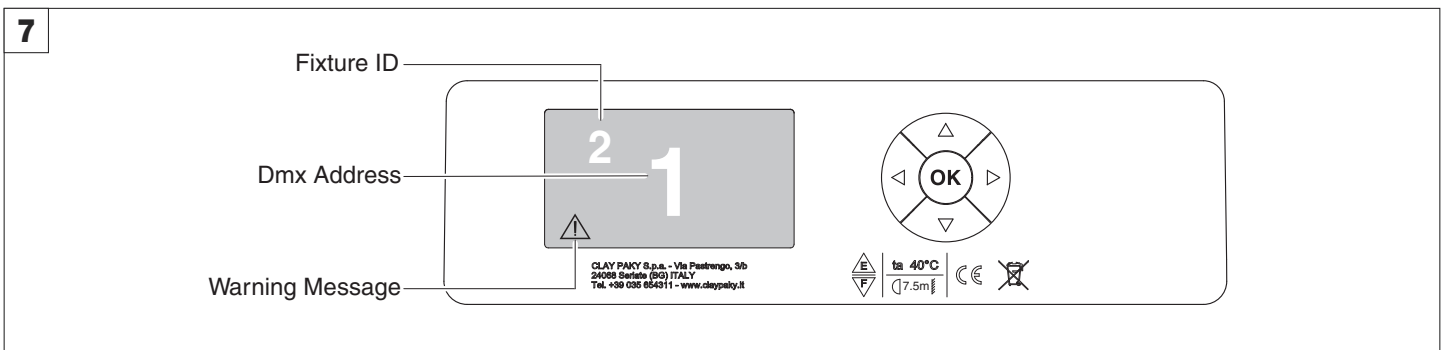

Switching on the projector - Fig. 7



Press the switch. The projector starts resetting the effects. At the same time, the following information scrolls on the display:

	Model A.leda Wash	Firmware Version X.X.X Date - Hour	xxx (Fixture ID) Dmx Address xxx	System errors E: W:
--	-----------------------------	---	--	--

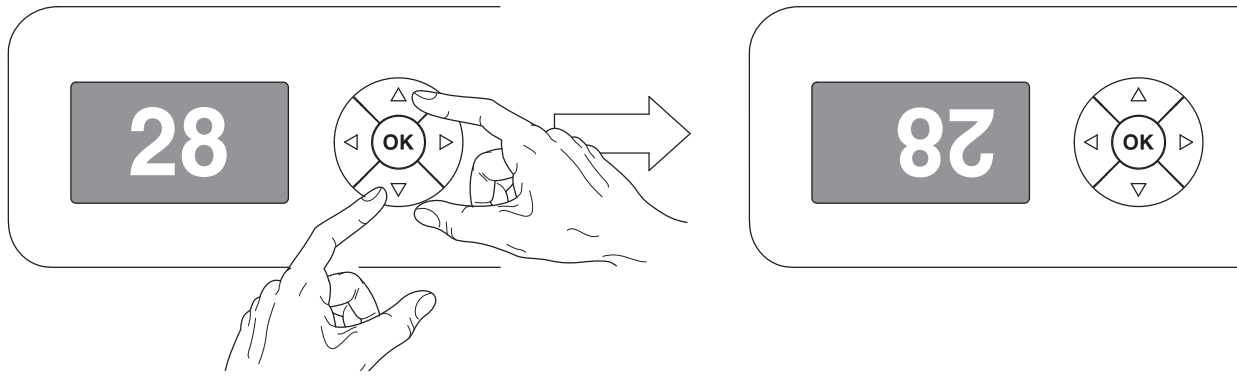
On conclusion of resetting in case of absence of the dm signal, Pan and Tilt move to the "Home" position (Pan 128 bit - Tilt 128 bit). The control panel (Fig. 7) has a display and buttons for the complete programming and management of the projector menu. The display can be in one of two conditions: rest status and setting status. When it is in the rest status, the display shows the projector's DMX address and the Fixture ID address (if set). During menu setting status, after a wait time (about 30 seconds) without any key having been pressed, the display automatically returns to rest status. It should be noted that when this condition occurs, any possible value that has been modified but not yet confirmed with the **OK** key will be cancelled.



Reversal of the display - Fig. 8

To activate this function, press UP  and DOWN  keys simultaneously while the display is in the rest mode. This status will be memorised and maintained even for the next time it will be switched on. To return to the initial state, repeat the operation all over again.

Setting the projector starting address

On each projector, the starting address must be set for the control signal (addresses from 1 to 512).

The address can also be set with the projector switched off.

Setting the projector Fixture ID

On each projector, the Fixture ID address must be set for an easy identification of the fixtures in an installation (ID from 1 to 255).

The Fixture ID address can be set with the projector switched off.

Functions of the buttons - Using the menu

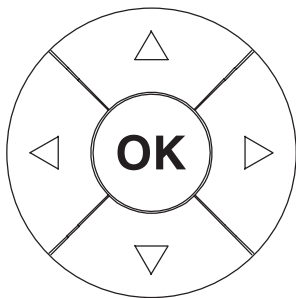

Confirms the displayed value, or activates the displayed function, or enters the successive menu.



DOWN

Decreases the value displayed (with auto-repetitions) or passes to the next item in the menu.



UP

Increases the value displayed (with auto-repetitions) or passes to the previous item in a menu.



LEFT







Return to the top level.



RIGHT

Commute from units, tens, hundreds, in the "Address", "Fixture ID" and "Calibration" menu.

USING THE MENU:

- 1) Press  once – "Main Menu" appears on the display.
- 2) Use the UP  and DOWN  keys to select the menu to be used:
 - Setup (Setup Menu): To set the setting options.
 - Option (Option Menu): To set the operating options
 - Informations (Informations Menu): To read the counters, software version and other information.
 - Manual Control (Manual control Menu): To trigger the test and manual control functions.
 - Test (Test Menu): To check the proper functioning of effects
 - Advanced (Advanced Menu): Access to the "Advanced menu" is recommended for a trained technical personnel.
- 3) Press  to display the first item in the selected menu.
- 4) Use the UP  and DOWN  keys to select the MENU items.

Setting addresses and options with the projector disconnected

The projector's DMX address, as well as other possible operating options, can also be set when the appliance is disconnected from the electricity supply. All that is needed is to press  to momentarily activate the display and thus access the settings. Once the required operations have been carried out, the display will switch off again after a wait time of 30 seconds.

MENU SETTING

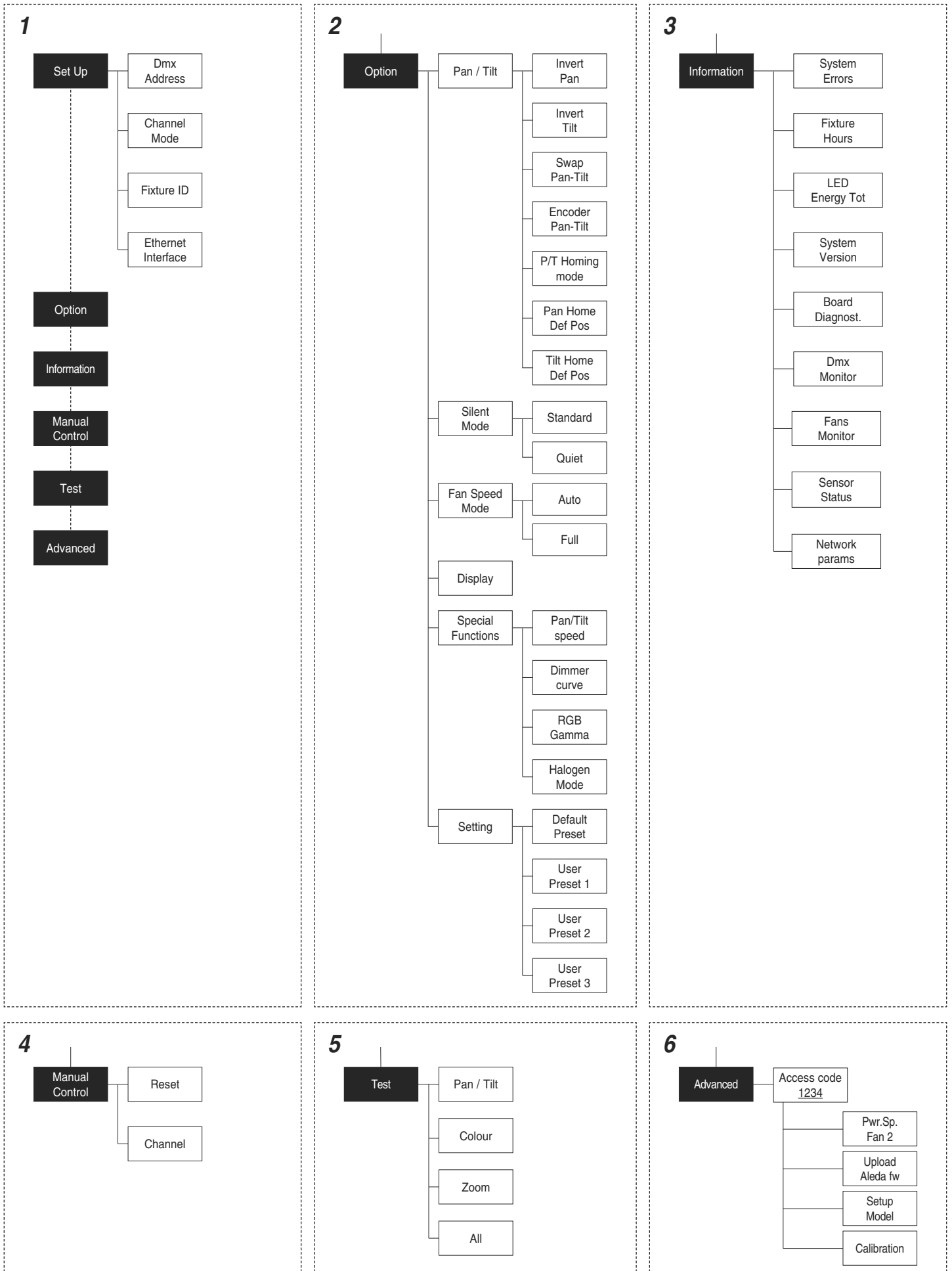

NOTE: On grey the default options

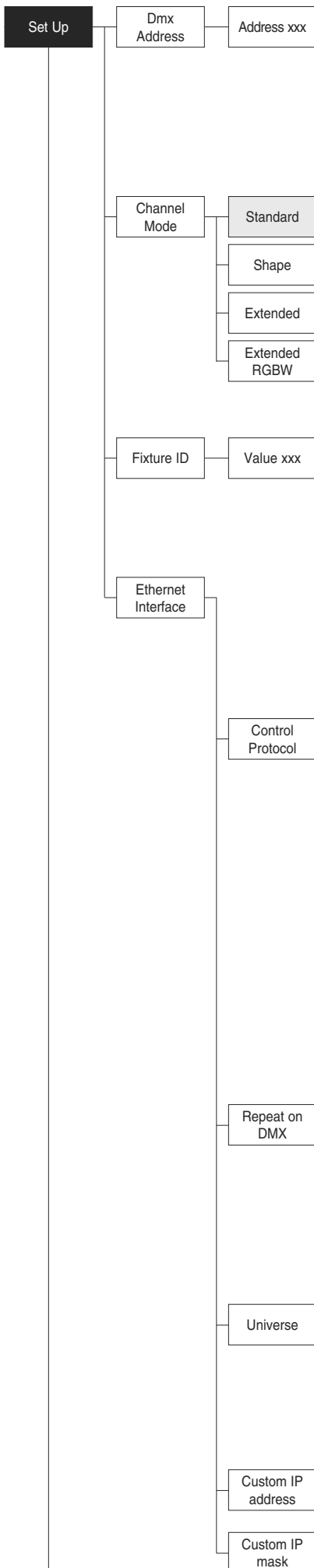

SET UP MENU

DMX ADDRESS

NOTE: without the DMX signal the Address (XXX) flashing

Allows you to select the DMX ADDRESS.

- 1) Press **OK** - the current DMX Address appear on the display.
- 2) Use the UP **▲** and DOWN **▼**, RIGHT **▶** keys to plan the DMX Address.
- 3) Press **OK** to confirm the selection or LEFT **◀** to keep current settings.

CHANNEL MODE

Allows you to select a channel arrangement from the four available.

- 1) Press **OK** - the current settings appear on the display.
- 2) Use the UP **▲** and DOWN **▼** keys to select one of the following settings:
 - **Standard**
 - **Shape**
 - **Extended**
 - **Extended RGBW**
- 3) Press **OK** to confirm the selection or LEFT **◀** to keep current settings.

FIXTURE ID

Allows you to select the FIXTURE ID.

- 1) Press **OK** - the current Fixture ID appear on the display.
- 2) Use the UP **▲**, DOWN **▼**, RIGHT **▶** keys to plan the Fixture ID.
- 3) Press **OK** to confirm the selection or LEFT **◀** to keep current settings.

ETHERNET INTERFACE

It lets you set the Ethernet settings to be attributed to the projector.

- 1) Premere **OK**.
- 2) Use the UP **▲** and DOWN **▼** keys to select the "Ethernet Interface" options to set:

Control Protocol

It lets you select the "Control Protocol" Art-net to assign according to the control unit used:

- 1) Press **OK** the current setting appears on the display.
- 2) Use the UP **▲** and DOWN **▼** keys to select one of the following settings:
 - Disabled
 - Art-net on IP 2
 - Art-net on IP 10
 - Art-net Custom IP
- 3) Press **OK** to confirm the selection or LEFT **◀** to keep the current setting.

If the **Control Protocol** option is set on **Disabled**, when an **IP** address (**IP2**, **IP10** or **IP Custom**) is selected, the projector immediately initializes the **IP** address that was just selected.

If the **Control Protocol** option is enabled (**IP2**, **IP10** or **IP Custom**) and a new one is selected that is different from the previous one, the projector must be restarted so that it will be correctly initialized.

Repeat on DMX

It lets you enable the transmission of the Ethernet protocol by DMX signal to all the connected projectors.

- 1) Press **OK** the current setting appears on the display.
- 2) Use the UP **▲** and DOWN **▼** keys to select one of the following settings:
 - **Disabled:** DMX transmission disabled.
 - **Enabled on primary:** DMX transmission enabled.
- 3) Press **OK** to confirm the selection or LEFT **◀** to keep the current setting.

Universe

It lets you assign the "Universe" number to be assigned to a series of projectors.

- 1) Press **OK** - the current Universe address appears on the display.
- 2) Use the UP **▲**, DOWN **▼**, RIGHT **▶** keys to set the Universe address.
- 3) Press **OK** to confirm the selection or LEFT **◀** to keep the current setting.

Custom IP address

Allows you to set the **IP address** manually by the user default.

Custom IP mask

Allows you to set manually the **Subnet Mask** by the user default.

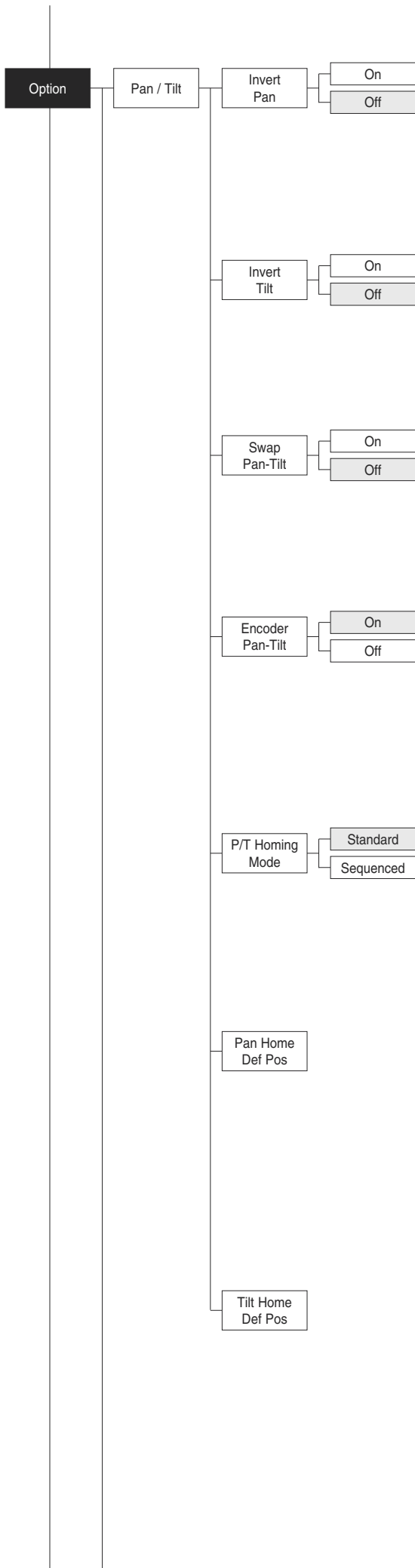

OPTIONS MENU

PAN / TILT

Invert pan

Used for reversing Pan movement.

- 1) Press **OK** - the current settings appear on the display (On or Off).
- 2) Use the UP **▲** and DOWN **▼** keys to enable (On) or disable (Off) PAN inversion.
- 3) Press **OK** to confirm the selection or LEFT **◀** to keep current settings.

Invert tilt

Used for reversing tilt movement.

- 1) Press **OK** - the current settings appear on the display (On or Off).
- 2) Use the UP **▲** and DOWN **▼** keys to enable (On) or disable (Off) Tilt inversion.
- 3) Press **OK** to confirm the selection or LEFT **◀** to keep current settings.

Swap Pan-Tilt

Used for swapping Pan and Tilt channels (as well as Pan fine and Tilt fine).

- 1) Press **OK** - the current settings appear on the display (On or Off).
- 2) Use the UP **▲** and DOWN **▼** keys to enable (On) or disable (Off) Pan and Tilt channel swap.
- 3) Press **OK** to confirm the selection or LEFT **◀** to keep current settings.

Encoder Pan-Tilt

Used for enabling the Pan / Tilt encoders.

- 1) Press **OK** - the current settings appear on the display (On or Off).
- 2) Use the UP **▲** and DOWN **▼** keys to enable (On) or disable (Off) Pan / Tilt encoders.
- 3) Press **OK** to confirm the selection or LEFT **◀** to keep current settings.

You can quickly disable the Pan and Tilt Encoder by simultaneously pressing the UP **▲ and DOWN **▼** keys in the "Main Menu".**

P/T Homing Mode

Lets you set the initial projector Reset mode.

- 1) Press **OK**, the current setting appears on the display.
- 2) Use the UP **▲** and DOWN **▼** keys to select one of the following settings:
 - Standard:** Pan & Tilt are simultaneously reset.
 - Sequenced:** Tilt is reset first followed by Pan.
- 3) Press **OK** to confirm the selection or LEFT **◀** to keep the current setting.

Pan Home Def Pos

Lets you assign the Pan channel "home" position at the end of Reset, without a DMX input signal.

- 1) Press **OK**, the current setting appears on the display.
- 2) Use the UP **▲** and DOWN **▼** keys to select one of the following settings:
 - 0 degree**
 - 90 degrees**
 - 180 degrees**
 - 270 degrees (default)**
- 3) Press **OK** to confirm the selection or LEFT **◀** to keep the current setting.

Tilt Home Def Pos

Lets you assign the Tilt channel "home" position at the end of Reset, without a DMX input signal.

- 1) Press **OK**, the current setting appears on the display.
- 2) Use the UP **▲** and DOWN **▼** keys to select one of the following settings:
 - 0%**
 - 12.5%**
 - 25%**
 - 50% (default)**
 - 75%**
 - 87.5%**
 - 100%**
- 3) Press **OK** to confirm the selection or LEFT **◀** to keep the current setting.

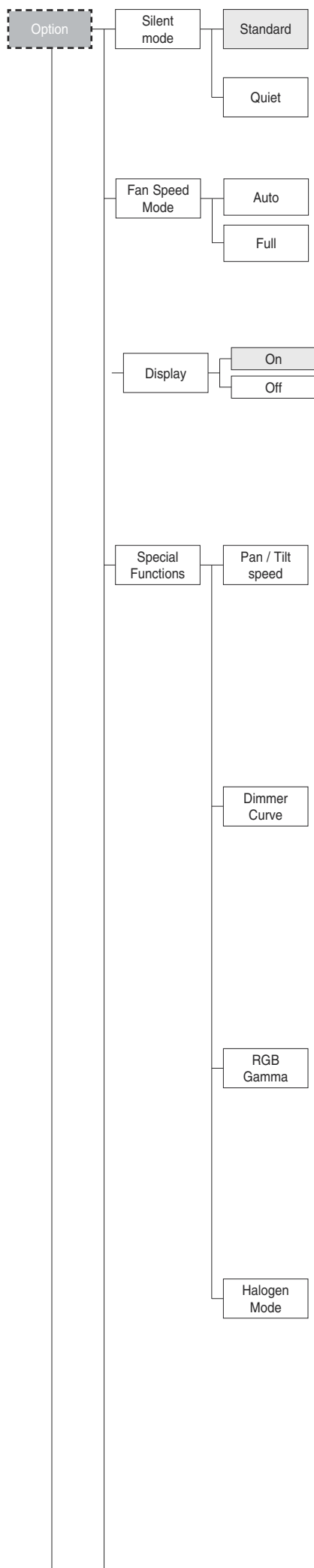

SILENT MODE

Lets you set an operator mode choosing from the two available:

- **Standard:** Maximum speed and consequently maximum effect and fan noise.
- **Quiet:** reduces the speed of some effects and fans thus also reducing noise.

FAN SPEED MODE

Allows you to set how to manage the fan speed of the head of the fixture, select between the two available:

- **Auto:** the head's fan varies the speed/power depending on the temperature detected on the LED.
- **Full:** the head's fan is always at full speed/power.

DISPLAY

Used for automatically reduce brightness on the display after about 30 seconds in idle.

- 1) Press **OK** - the current settings appear on the display (On or Off).
- 2) Use the UP **▲** and DOWN **▼** keys to enable (On) or disable (Off) the decreasing of display brightness.
- 3) Press **OK** to confirm the selection or LEFT **◀** to keep current settings.

SPECIAL FUNCTIONS

Pan / Tilt speed

Lets you select two different Pan and Tilt speeds.

- 1) Press **OK** - the current setting appears on the display.
- 2) Use the UP **▲** and DOWN **▼** keys to select one of the following settings:
 - **Normal**
 - **Fast**
- 3) Press **OK** to confirm the selection or LEFT **◀** to keep current settings.

Dimmer Curve

Lets you select four different Dimmer channel curves.

- 1) Press **OK** - the current setting appears on the display.
- 2) Use the UP **▲** and DOWN **▼** keys to select one of the following settings:
 - **Curve 1**
 - **Curve 2**
 - **Curve 3**
 - **Curve 4**
- 3) Press **OK** to confirm the selection or LEFT **◀** to keep current settings.

RGB Gamma

Lets you select three different RGBW gamma curves.

- 1) Press **OK** - the current setting appears on the display.
- 2) Use the UP **▲** and DOWN **▼** keys to select one of the following settings:
 - **Gamma 1.0**
 - **Gamma 1.5**
 - **Gamma 2.0**
- 3) Press **OK** to confirm the selection or LEFT **◀** to keep current settings.

Halogen Mode

Lets you select five different halogen lamp simulations.

- 1) Press **OK** - the current setting appears on the display.
- 2) Use the UP **▲** and DOWN **▼** keys to select one of the following settings:
 - **Halogen OFF**
 - **Halogen Lamp 1**
 - **Halogen Lamp 2**
 - **Halogen Lamp 3**
 - **Halogen Lamp 4**
 - **Halogen Lamp 5**
- 3) Press **OK** to confirm the selection or LEFT **◀** to keep current settings.

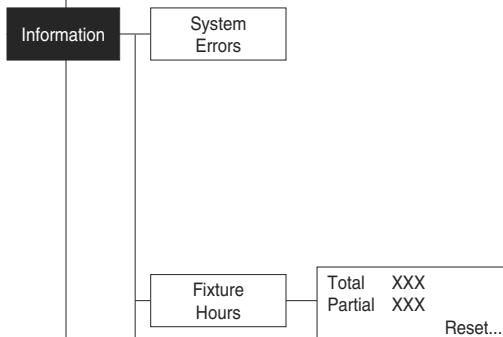
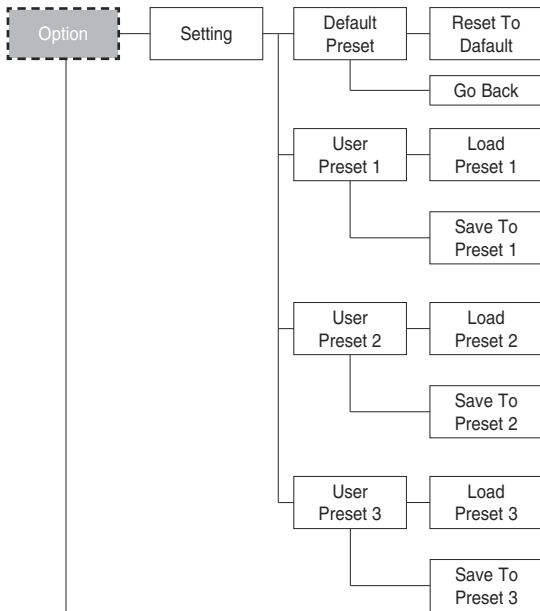

SETTING

Used to save 3 different settings of the items in the options menu and relative submenus.

- 1) Press **OK** - "Default preset" appears on the display.
- 2) Use the UP **▲** and DOWN **▼** keys to select one of the following configurations:
 - Default preset (*)
 - User preset 1
 - User preset 2
 - User Preset 3
- 3) Press **OK** - "Load preset X" appears on the display.
- 4) Use the UP **▲** and DOWN **▼** keys to select:
 - Load preset X to recall a previously stored configuration.
 - Save to preset X to store the current configuration.
 a confirmation message (Are you sure?) appears on the display.
- 5) Select YES to confirm the selection or NO to keep the current setting and return to the next higher level.

(*) DEFAULT PRESET

By pressing the RIGHT **▶ key and the LEFT **◀** key simultaneously once entered in the "main menu" it is possible to quickly (short cut) reset the default settings (DEFAULT PRESET).**

Used for restoring default values on all options menu items and relevant submenus.

- 1) Press **OK**, a confirmation message (Are you sure?) appears on the display.
- 2) Select YES to confirm the selection or NO to keep current setting.

OPTION	DEFAULT
Invert Pan	Off
Invert Tilt	Off
Swap Pan-Tilt	Off
Encoder Pan-Tilt	On
P/T Homing Mode	Standard
Pan Home Def Pos	270 degrees
Tilt Home Def Pos	50%
Display	On
Silent Mode	Standard
Fan Speed Mode	Auto
P/T Speed	Fast
Dimmer Curve	Curve 1
RGB Gamma	Gamma 1.5
Halogen Mode	Halogen Off

INFORMATION MENU

SYSTEM ERRORS

Shows a list of warnings and messages relevant to errors occurred since the fixtures switching-on.

- 1) Pressing **OK** you are allowed to reset the SYSTEM ERRORS list.
A confirmation message (Are you sure you want to clear error list ?) appears on the display.
- 2) Select YES to reset the list or NO to go back.

FIXTURE HOURS

Used for displaying projector operating hours (total and partial).

- 1) Press **OK** - Hours total and partial appears on the display.

Total counter

Counts the number of projector working life hours (from manufacture to date).

Partial counter

Counts the number of partial projector working life hours since the last reset to date.

- 2) Press **OK** to reset partial projector working hours a confirmation message (Are you sure?) appears on the display.
- 3) Select YES to reset partial projectors counter or NO to keep the current setting and return to the top menu level.

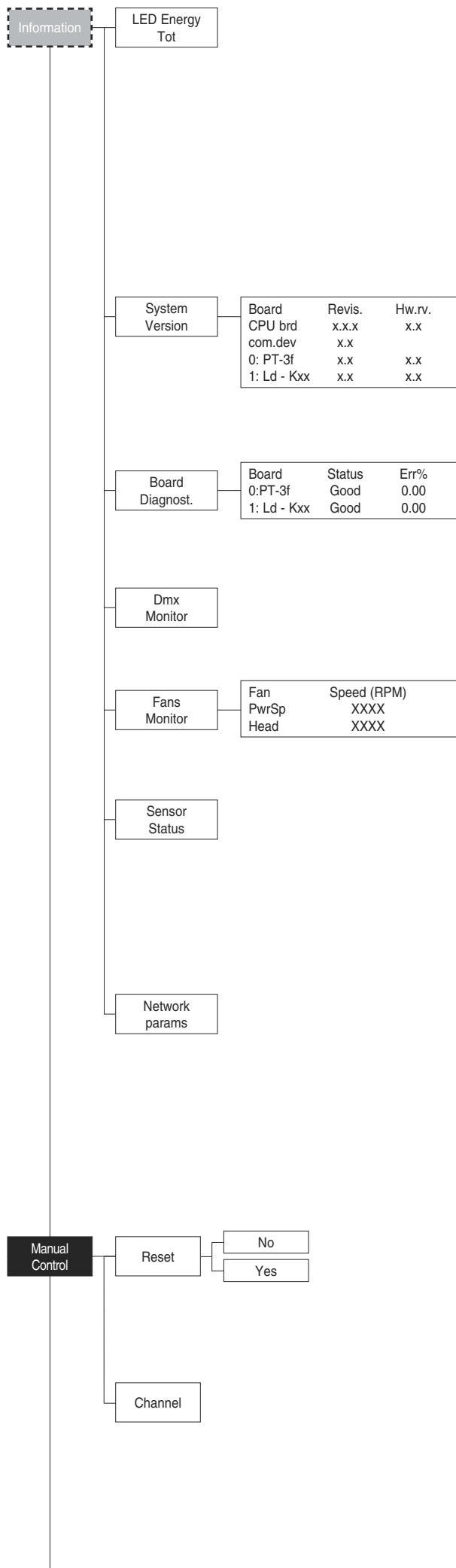

LED ENERGY TOT

Lets you view total LED working hours.

- 1) Press **OK** - to display total and partial Watts/hour:

Total

Total LED working hours from construction to date.

Partial

LED working hours from last reset to date.

- 2) Press **OK** to reset the partial counter. A confirmation appears on the screen (Are you sure?)
- 3) Select YES to reset the partial counter or NO to keep the current setting and open the next menu level.

SYSTEM VERSION

Used for displaying the software and hardware version of each board installed in the projector.

CPU brd (CPU board)

0: PT-3f (Scheda Pan / Tilt)

1: Ld - Kxx (Scheda LED)

Board	Revis.	Hw.rv.
CPU brd	x.x.x	x.x
com.dev	x.x	
0: PT-3f	x.x	x.x
1: Ld - Kxx	x.x	x.x

BOARD DIAGNOSTIC

Used for displaying the status error of each board installed in the projector:

0: PT-3f (Scheda Pan / Tilt)

1: Ld - Kxx (Scheda LED)

Board	Status	Err%
0:PT-3f	Good	0.00
1: Ld - Kxx	Good	0.00

DMX MONITOR

Used for displaying the projector DMX channel level in bit (Val) and in percentage (Perc).

FANS MONITOR

Used for displaying the speed of each fan installed in the projector:

PwrSp (fan PSU)

Head (fan head)

Fan	Speed (RPM)
PwrSp	XXXX
Head	XXXX

SENSOR STATUS

It lets you check the correct operations of each "sensor" installed in the projector, each channel is associated with one of the following three parameters:

- n.a.= sensor not available
- ON= sensor working
- OFF= sensor defective

NETWORK PARAMS

Allows the "Network" parameters of the projector to be displayed or:

IP address: Internet Protocol address (two projectors must not have the same IP address)

IP mask: 255.0.0.0

Mac address: Media Access Control: the projector's Ethernet Address.

MANUAL CONTROL

RESET

Used for resetting the projector.

- 1) Press **OK** to reset the projectors, a confirmation message (Are you sure ?) appears on the display.
- 2) Select YES to starting reset the fixture or NO to keep the current setting and return to the top menu level.

CHANNEL

Used for setting channel levels from the projector control panel.

- 1) Press **OK** - the first channel appears on the display.
- 2) Use the UP **▲** and DOWN **▼** keys to select the required channel:
- 3) Press **OK** and use the UP **▲** and DOWN **▼** keys to select the required DMX level (value between 0 and 255).
- 4) Press LEFT **←** to return to the top menu level.

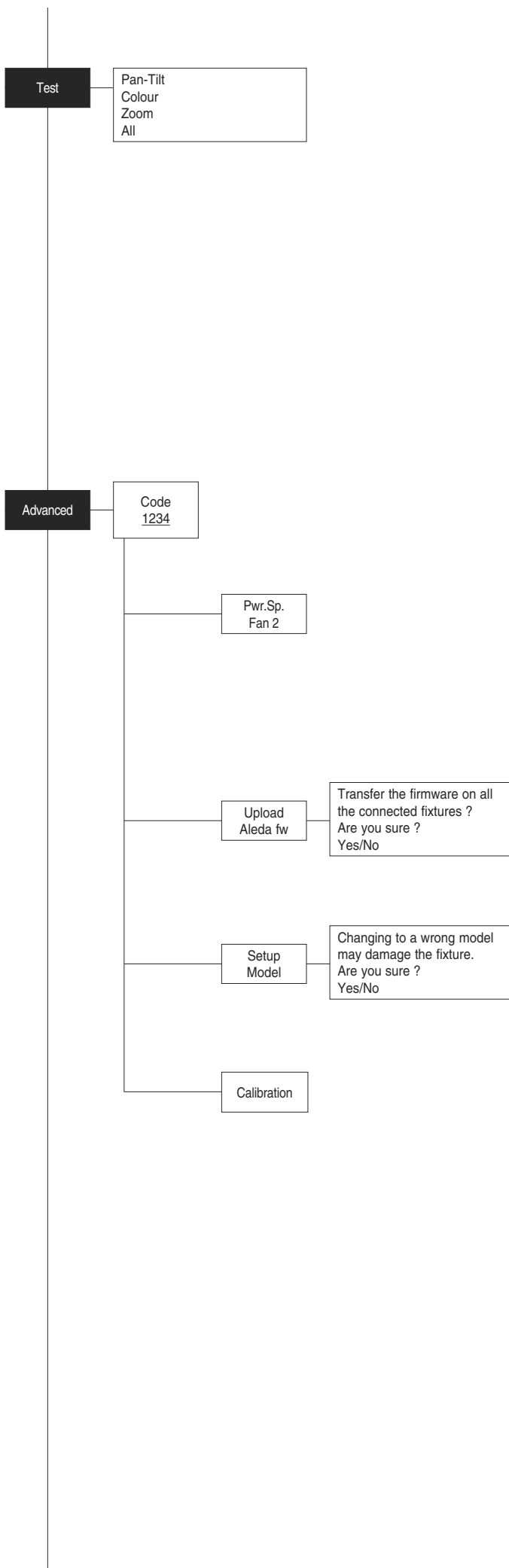

TEST MENU

TEST

Allows you to check the proper functioning of effects.

- 1) Press **OK** to return to the top menu level.
- 2) Use the UP **▲** and DOWN **▼** keys to select the required test.
- 3) Press **OK** to confirm the selection or LEFT **◀** to keep current settings.

Test sequence:

Pan - Tilt effects (Pan & Tilt)

Colours

Zoom

All effects

ADVANCED MENU

To enable the "Advanced Menu" set up the "Access code" (1234) using the UP **▲**, DOWN **▼**, RIGHT **▶** keys.

Press **OK** - "Menu advanced" appears on the display

POWER SUPPLY FAN 2 (only for A.leda Wash K20)

Lets you turn the PSU second cooling fan control on/off.

- **On:** Fan on (as per last specifications).
- **Off:** Fan off; the first A.leda Wash K20 lots (prior to projector with serial number AC019438), were constructed with a single PSU cooling fan, a firmware update could cause fault signals, disabling the fan, no error will be displayed.

UP LOAD FIRMWARE

Allows you to transfer the firmware from 1 fixture to all the connected fixtures.

- 1) Press **OK**, a confirmation message appears on the display.
- 2) Select YES to start the firmware loading or NO to keep the current setting and return to the top menu level

SETUP MODEL

Allows you to change the default model of projector.

- 1) Press **OK** a confirmation message appears on the display.
- 2) Select YES to define the model of projector or NO to keep the current setting and return to the top menu level.

CALIBRATION

Allows you to adjust effects from the control panel to obtain perfect uniformity between the projectors.

- 1) Press **OK** - "channels" appears on the display.
- 2) Using the UP **▲** and DOWN **▼** keys, select the effect you wish to regulate.
- 3) Press **OK** and use the RIGHT **▶**, UP **▲** and DOWN **▼** buttons to make the adjustment by setting a value between 0 and 255.
- 4) Press **OK** to confirm the selection or LEFT **◀** to keep current settings and return to the top level.

FACTORY DEFAULT

Allows you to restore default values of all channels (128).

- 1) Press **OK** - a confirmation message appears on the display (Reset calibration to factory default ?).
- 2) Select YES to reset calibration to factory default or NO to keep the current setting and return to the top menu level.

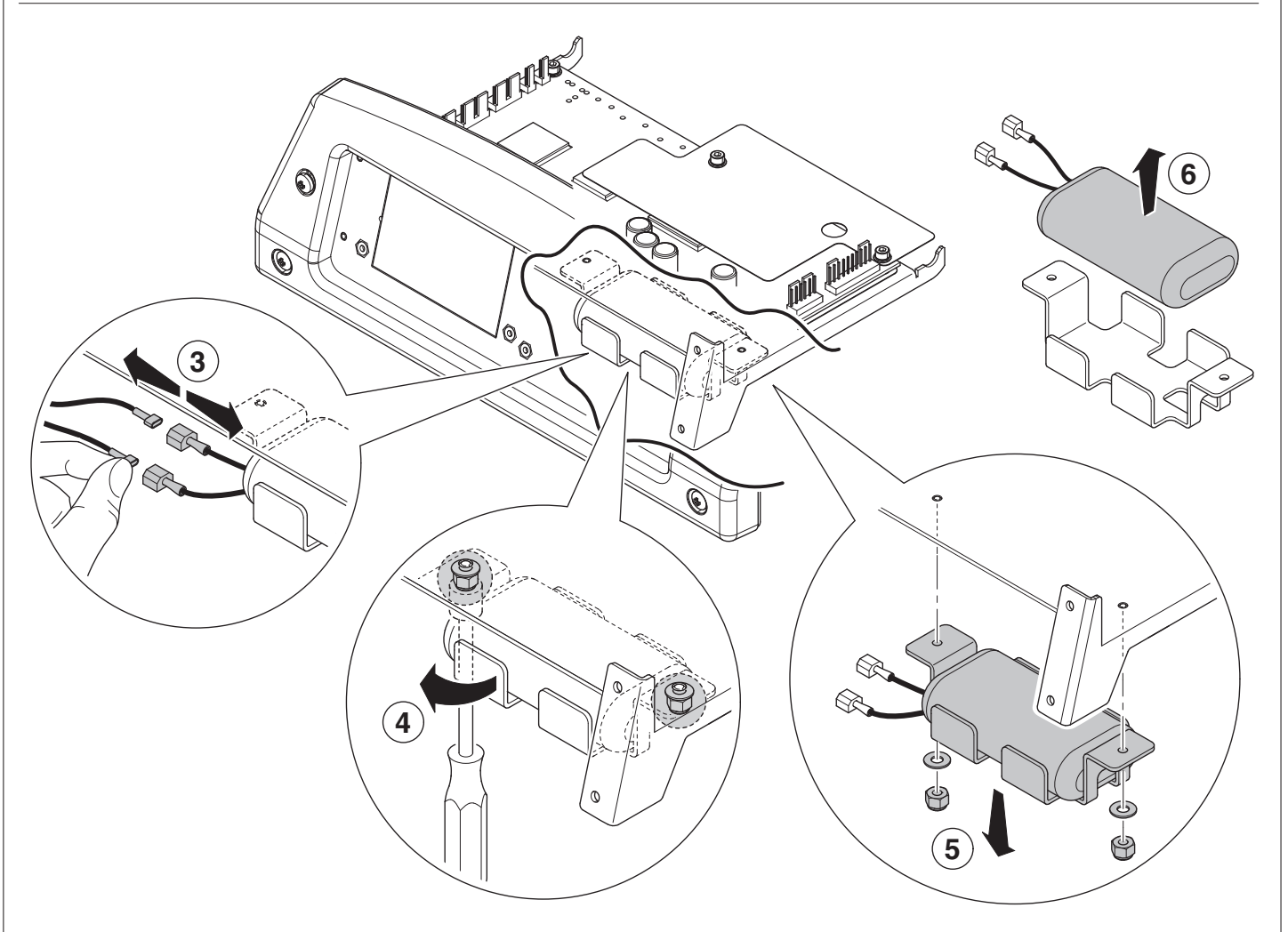
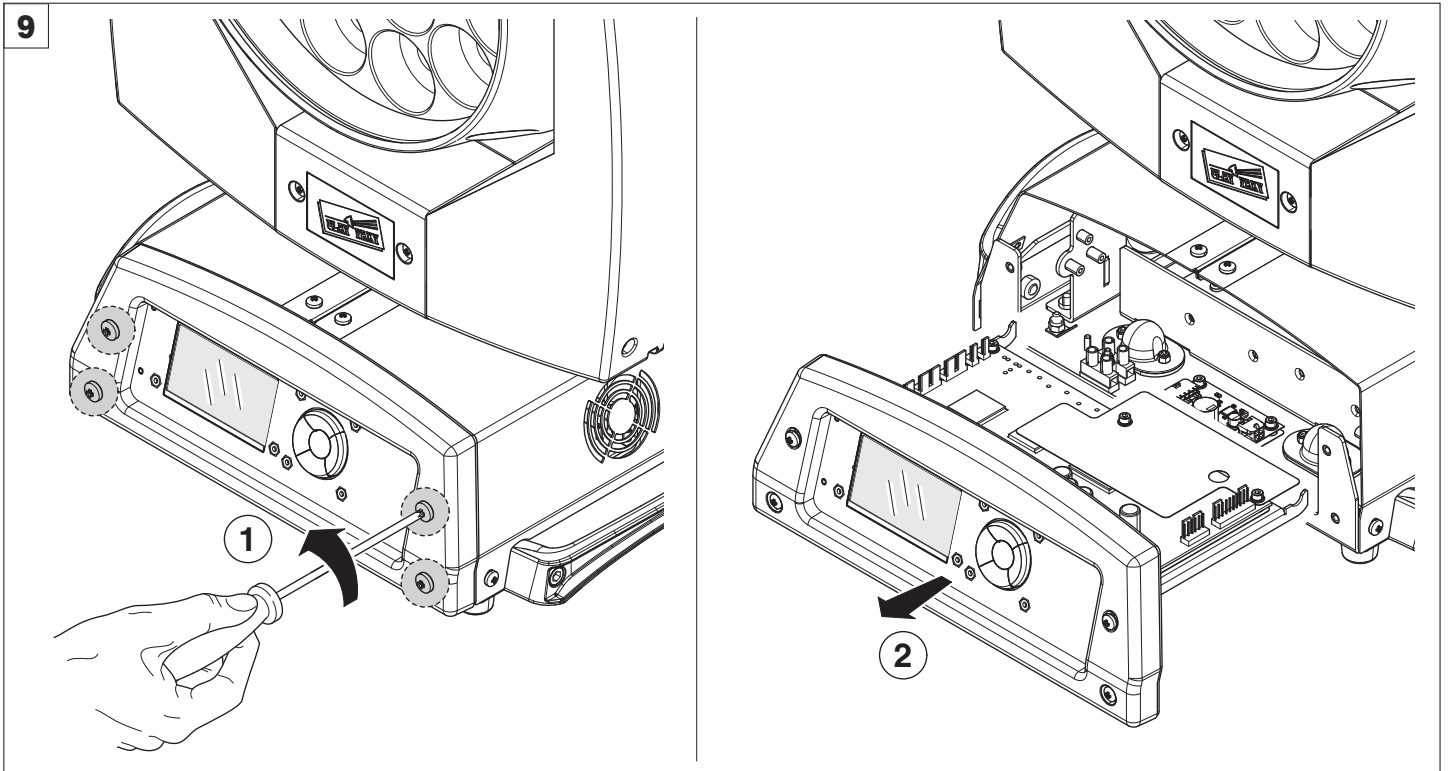

Battery removal - Fig. 9



This product contains a rechargeable lithium iron tetraphosphate battery. To preserve the environment, please dispose the battery at the end of its life according to the regulation in force.

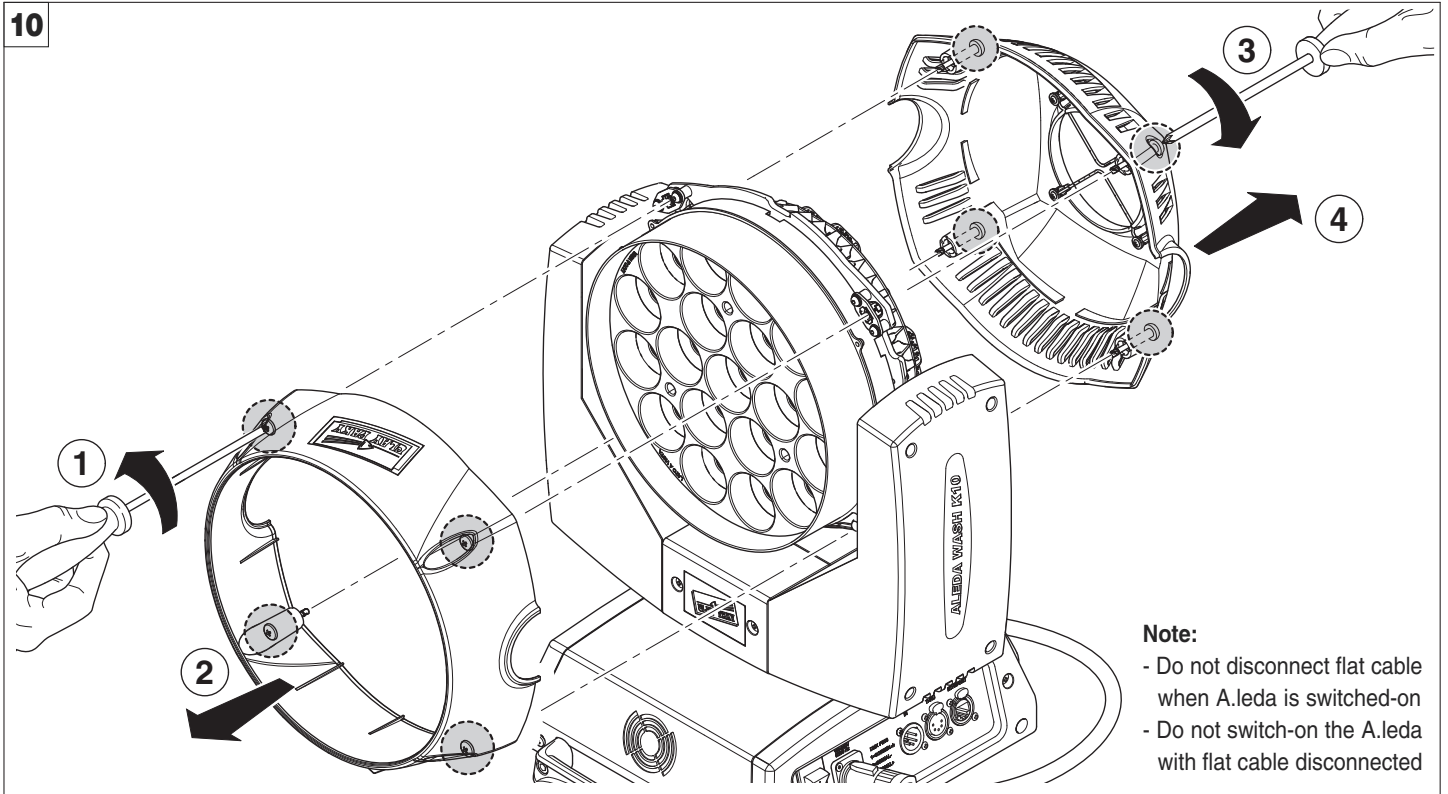

Note:
 - Do not disconnect flat cable when A.leda is switched-on
 - Do not switch-on the A.leda with flat cable disconnected

Opening the covers - Fig. 10

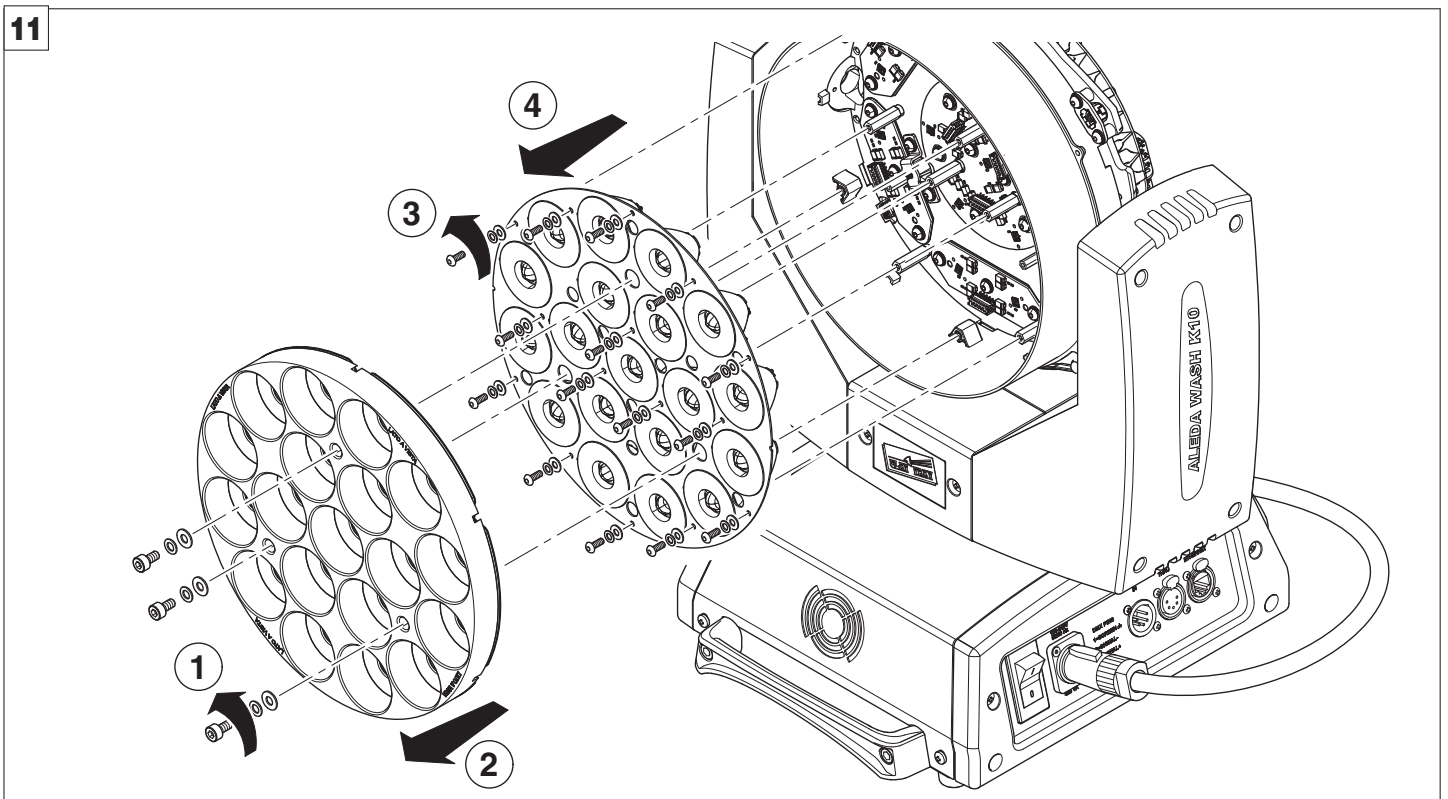

Removing/Assembling the lens unit - Fig. 11

NB: Apply Loctite 222 (p/n COL002) to the threads of the 3 screws (1) before tightening them. A torque of 0.3N is recommended in order to avoid damaging the zoom movement actuators.

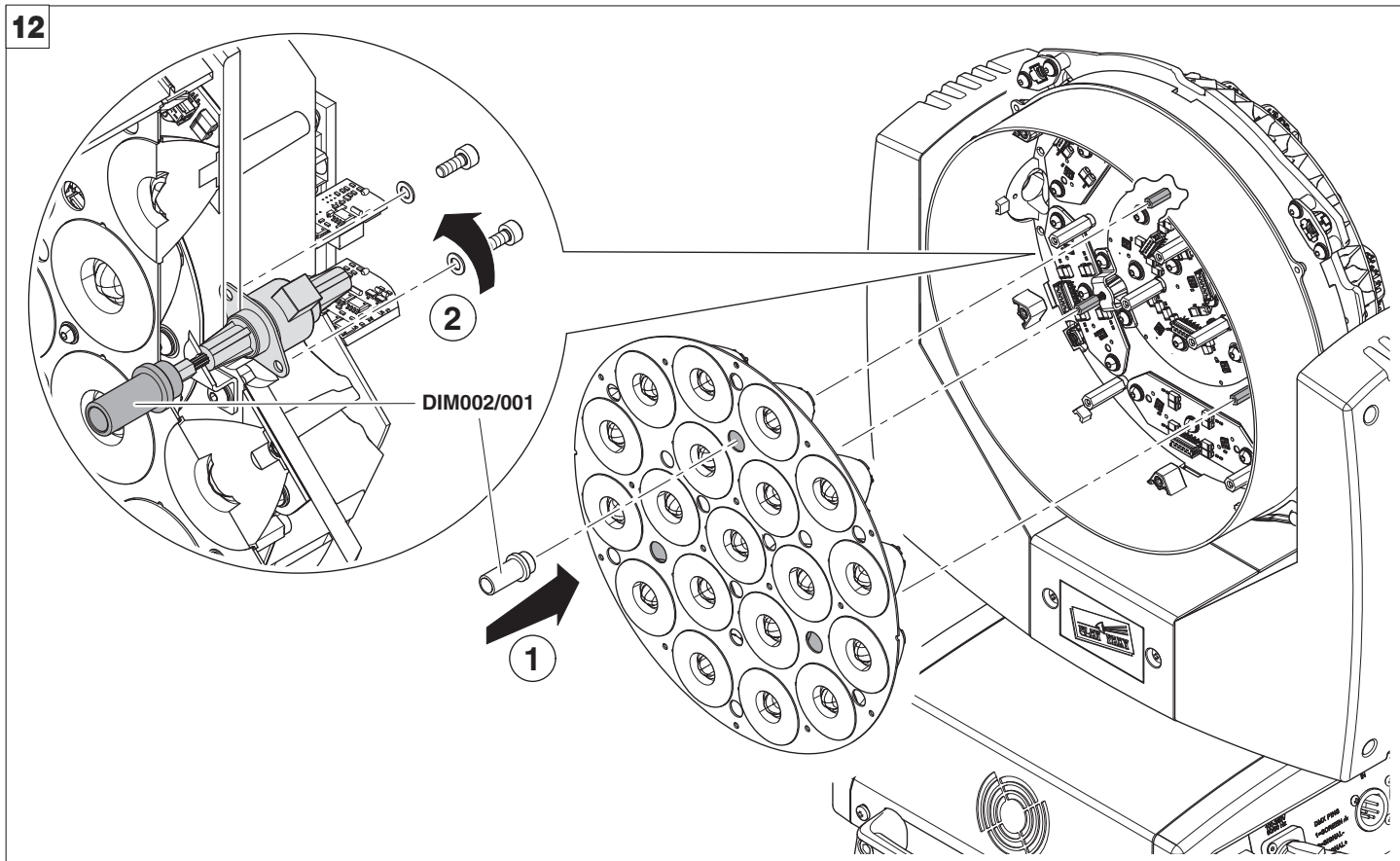

Replacing the line actuator - Fig. 12

NB: It is highly recommended to use the DIM002/001 (1) template whenever it is necessary to replace one of the three Zoom movement line actuators. DIM002/001 ensures the actuator group is centred correctly on the lens plate before tightening the 2 screws (2) that fasten the actuator in place.

A.LEDA WASH K10

15

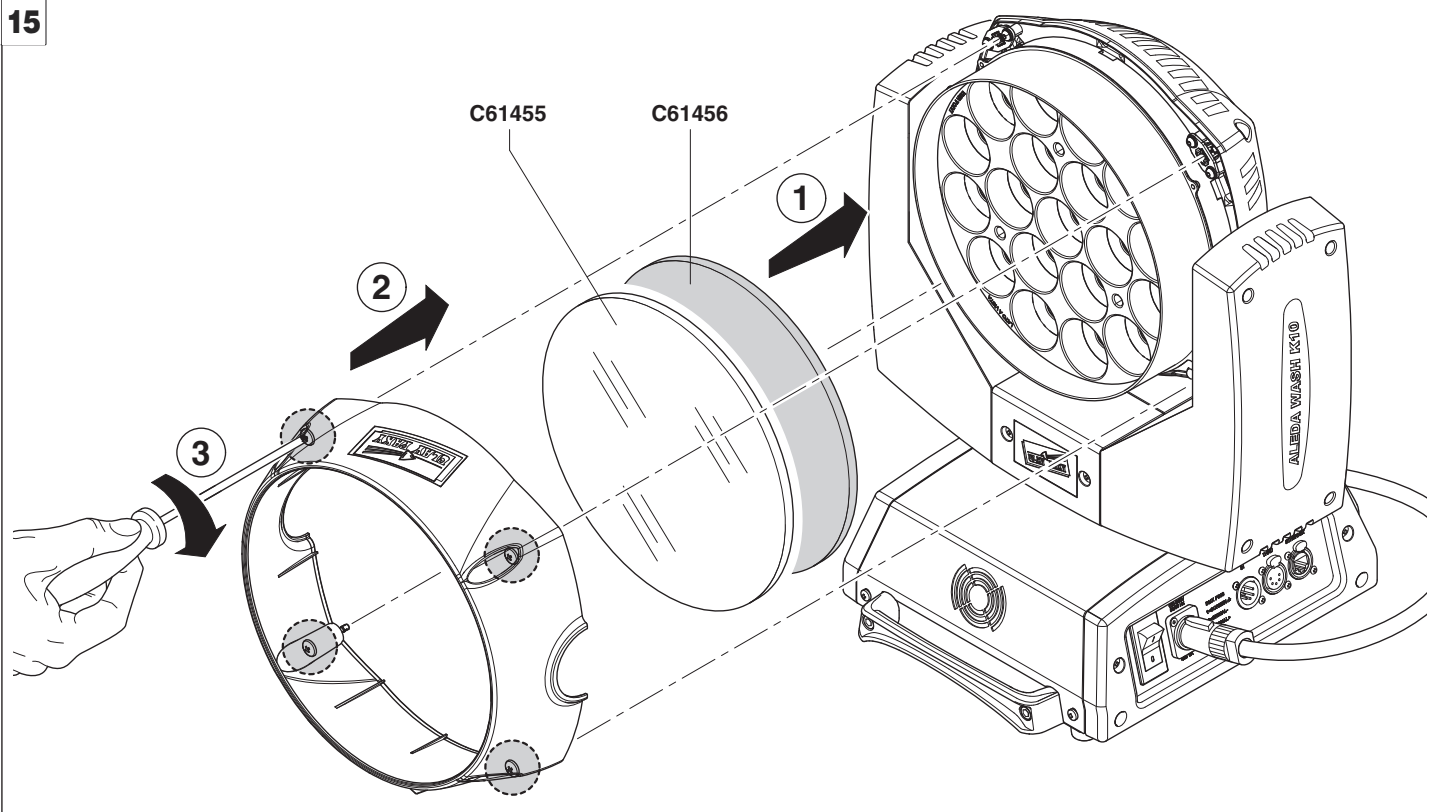

Cover - Fig. 15

C61455 - Transparent cover

C61456 - Frosted cover

16

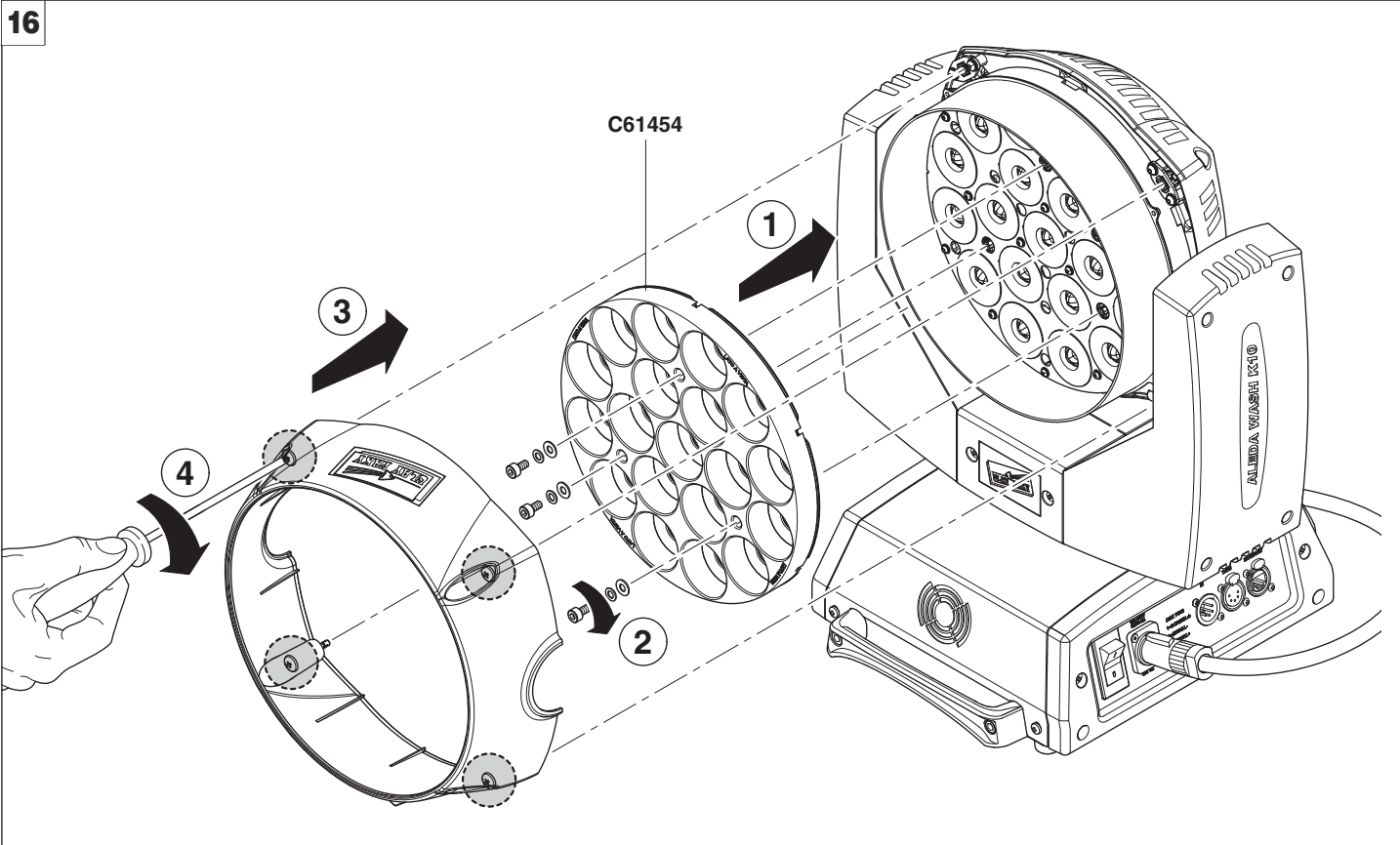

Transparent mask - Fig. 16

A.LEDA WASH K20

17

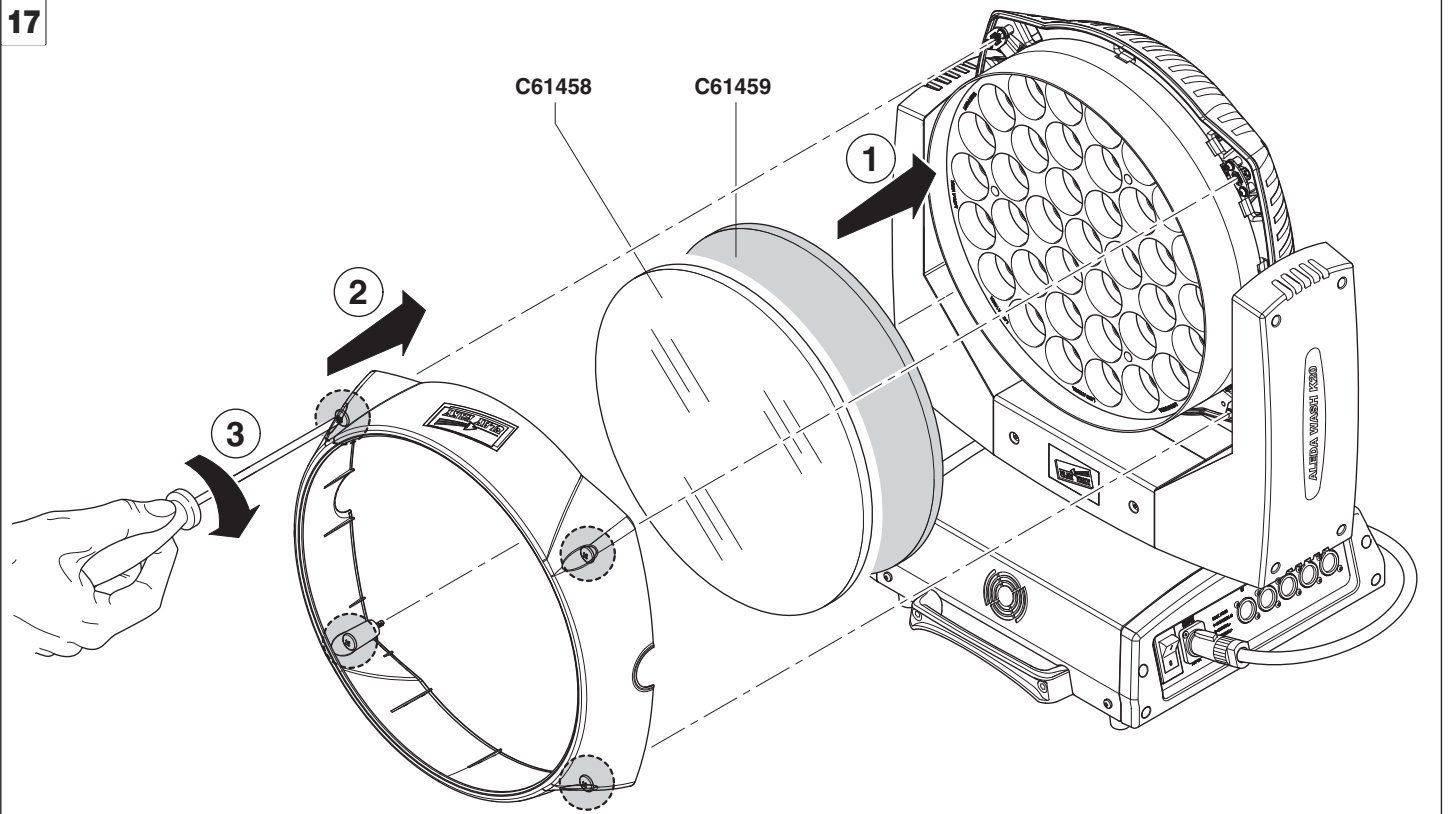

Cover - Fig. 17

C61458 - Transparent cove

C61459 - Frosted cover

18

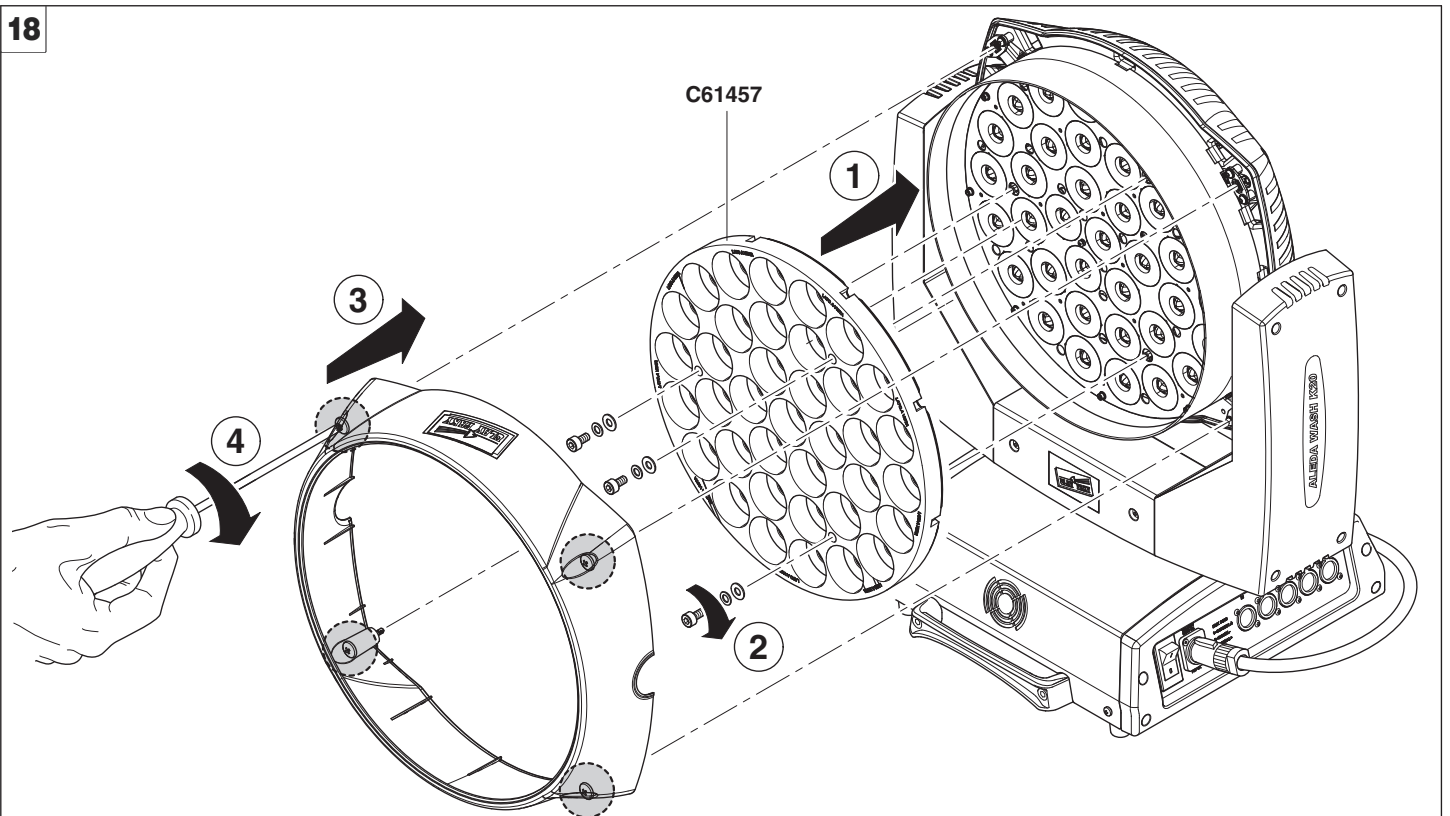

Transparent mask - Fig. 18

TECHNICAL INFORMATION

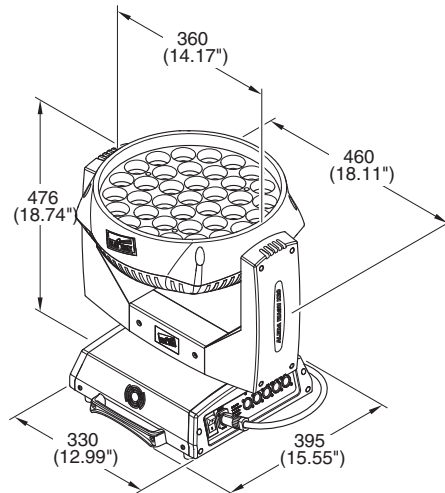
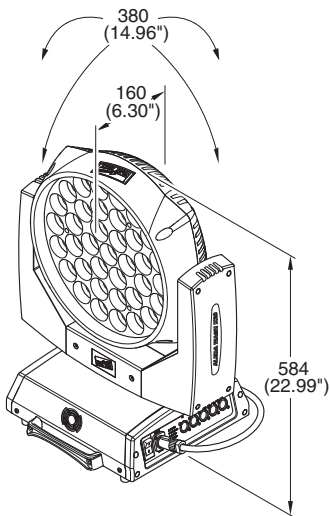
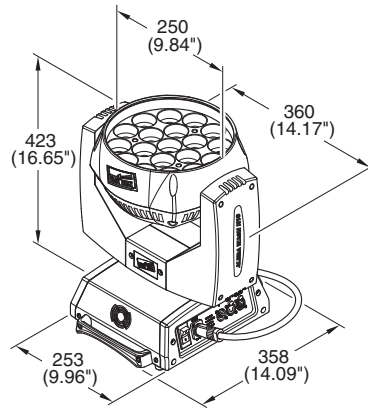
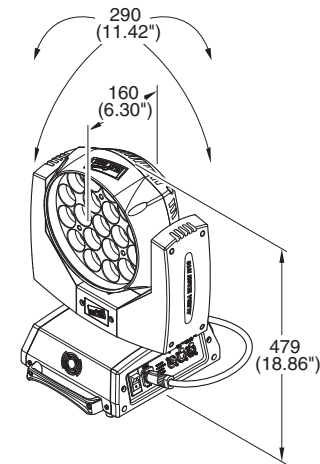

Power supplies available
100-240V 50/60Hz

Input power
• K20 - 750VA
• K10 - 450VA

Total output
K10 - Max 5500 lumens
K20 - Max 10500 lumens

LED source
Osram Ostar RGBW - 15W - LED
Average LED life: 50.000 h

Motors
5 (k10 & k20), stepper motors, operating with microsteps, totally microprocessor controlled.

Cooling
• High efficiency die-cast aluminium
• Forced ventilation

Inputs
• DMX 512
• Ethernet

Working position
Working in any position.

Moving Head
• Movement by means of two stepper motors, controlled by microprocessor.
• Automatic repositioning of PAN and TILT after accidental movement not controlled by control unit.
• Angle:
- PAN = 540°
- TILT = 270°

IP20 protection rating
• Protected against the entry of solid bodies larger than 12mm (0.47").
• No protection against the entry of liquids.

Weights
• K10: 14 Kg (30.8 lbs)
• K20: 19.5 Kg (43 lbs)

CAUSE AND SOLUTION OF PROBLEMS

THE PROJECTOR WILL NOT SWITCH ON			PROBLEMS
ELECTRONICS NON-OPERATIONAL			
DEFECTIVE PROJECTION			
REDUCED LUMINOSITY			
POSSIBLE CAUSES		CHECKS AND REMEDIES	
●		No mains supply.	Check the power supply voltage.
●	●	LED exhausted or defective.	Call an authorised technician.
●		Signal transmission cable faulty or disconnected.	Replace the cables.
●		Incorrect addressing.	Check addresses (see instructions).
●		Fault in the electronic circuits.	Call an authorised technician.
	●	Lenses or reflector broken	Call an authorised technician.
	● ●	Dust or grease deposited.	Clean (see instructions).

A.LEDA WASH K10

NB: To prevent accidental breakage of the effects, which could collide with each other during transport, before switching the projector OFF check that all the projector Channels have been excluded (DMX level @0 bit).

STANDARD

CHAN-NEL	CHANNEL MODE
1	Red
2	Red fine
3	Green
4	Green fine
5	Blue
6	Blue fine
7	White
8	White fine
9	Linear CTO
10	Macro colour
11	Strobe
12	Dimmer
13	Dimmer Fine
14	Pan
15	Pan Fine
16	Tilt
17	Tilt Fine
18	Function
19	Reset
20	Zoom

SHAPES

CHAN-NEL	CHANNEL MODE
1	Red
2	Red fine
3	Green
4	Green fine
5	Blue
6	Blue fine
7	White
8	White fine
9	Linear CTO
10	Macro colour
11	Strobe
12	Dimmer
13	Dimmer Fine
14	Pan
15	Pan Fine
16	Tilt
17	Tilt Fine
18	Function
19	Reset
20	Zoom
21	Shape Selection
22	Shape Speed
23	Shape Fade
24	Shape R
25	Shape G
26	Shape B
27	Shape W
28	Shape Dimmer
29	Background Dimmer
30	Shape Transition
31	Shape Offset

EXTENDED

CHAN-NEL	CHANNEL MODE
1	Red
2	Red fine
3	Green
4	Green fine
5	Blue
6	Blue fine
7	White
8	White fine
9	Linear CTO
10	Macro colour
11	Strobe
12	Dimmer
13	Dimmer Fine
14	Pan
15	Pan Fine
16	Tilt
17	Tilt Fine
18	Function
19	Reset
20	Zoom
21	Red LED 1
22	Green LED 1
23	Blue LED 1
...	Red LED ...
...	Green LED ...
...	Blue LED ...
75	Red LED 19
76	Green LED 19
77	Blue LED 19

EXTENDED RGBW

CHAN-NEL	CHANNEL MODE
1	Red
2	Red fine
3	Green
4	Green fine
5	Blue
6	Blue fine
7	White
8	White fine
9	Linear CTO
10	Macro colour
11	Strobe
12	Dimmer
13	Dimmer Fine
14	Pan
15	Pan Fine
16	Tilt
17	Tilt Fine
18	Function
19	Reset
20	Zoom
21	Red LED 1
22	Green LED 1
23	Blue LED 1
24	White LED 1
...	Red LED ...
...	Green LED ...
...	Blue LED ...
...	White LED ...
93	Red LED 19
94	Green LED 19
95	Blue LED 19
96	White LED 19

A.LEDA WASH K20

NB: To prevent accidental breakage of the effects, which could collide with each other during transport, before switching the projector OFF check that all the projector Channels have been excluded (DMX level @0 bit).

STANDARD

CHAN-NEL	CHANNEL MODE
1	Red
2	Red fine
3	Green
4	Green fine
5	Blue
6	Blue fine
7	White
8	White fine
9	Linear CTO
10	Macro colour
11	Strobe
12	Dimmer
13	Dimmer Fine
14	Pan
15	Pan Fine
16	Tilt
17	Tilt Fine
18	Function
19	Reset
20	Zoom

SHAPES

CHAN-NEL	CHANNEL MODE
1	Red
2	Red fine
3	Green
4	Green fine
5	Blue
6	Blue fine
7	White
8	White fine
9	Linear CTO
10	Macro colour
11	Strobe
12	Dimmer
13	Dimmer Fine
14	Pan
15	Pan Fine
16	Tilt
17	Tilt Fine
18	Function
19	Reset
20	Zoom
21	Shape Selection
22	Shape Speed
23	Shape Fade
24	Shape R
25	Shape G
26	Shape B
27	Shape W
28	Shape Dimmer
29	Background Dimmer
30	Shape Transition
31	Shape Offset

EXTENDED

CHAN-NEL	CHANNEL MODE
1	Red
2	Red fine
3	Green
4	Green fine
5	Blue
6	Blue fine
7	White
8	White fine
9	Linear CTO
10	Macro colour
11	Strobe
12	Dimmer
13	Dimmer Fine
14	Pan
15	Pan Fine
16	Tilt
17	Tilt Fine
18	Function
19	Reset
20	Zoom
21	Red LED 1
22	Green LED 1
23	Blue LED 1
...	Red LED ...
...	Green LED ...
...	Blue LED ...
129	Red LED 37
130	Green LED 37
131	Blue LED 37

EXTENDED RGBW

CHAN-NEL	CHANNEL MODE
1	Red
2	Red fine
3	Green
4	Green fine
5	Blue
6	Blue fine
7	White
8	White fine
9	Linear CTO
10	Macro colour
11	Strobe
12	Dimmer
13	Dimmer Fine
14	Pan
15	Pan Fine
16	Tilt
17	Tilt Fine
18	Function
19	Reset
20	Zoom
21	Red LED 1
22	Green LED 1
23	Blue LED 1
24	White LED 1
...	Red LED ...
...	Green LED ...
...	Blue LED ...
...	White LED ...
165	Red LED 37
166	Green LED 37
167	Blue LED 37
168	White LED 37

NOTE: On conclusion of resetting in case of absence of DMX signal, Pan & Tilt move to the "Home" position (Pan bit 128 - Tilt bit 128) all the others channels stay @ bit 0.

- RED
- GREEN
- BLUE
- WHITE



BIT	EFFECT
255	MAXIMUM BRIGHTNESS
0	LED OFF

- RED FINE
- GREEN FINE
- BLUE FINE
- WHITE FINE



BIT	EFFECT
255	UPPER BRIGHTNESS
0	LOWER BRIGHTNESS

- LINEAR CTO

BIT	EFFECT
255	2500 K
...	...
224	3200 K
...	...
188	4000 K
...	...
144	5000 K
...	...
117	5600 K
...	...
99	6000 K
...	...
54	7000 K
...	...
10	8000 K
0-9	UNUSED RANGE

Note: If CTO channel is active, the WHITE channel is disabled.

- MACRO COLOUR

BIT	LEE REFERENCE	COLOUR	BIT VALUE			
			R	G	B	W
209-255	-	White	255	235	66	255
208	-	Dirty White	255	255	122	255
207	197	Alice Blue	128	255	143	0
191-206	181	Congo Blue	77	0	255	0
184-190	174	Dark Steel Blue	181	255	95	0
180-183	170	Deep lavender	255	168	64	0
179	169	Lilac Tint	255	199	49	0
175-178	165	Daylight Blue	82	214	90	0
174	164	Flame Red	255	46	2	0
172-173	162	Bastard Amber	255	181	28	0
168-171	158	Deep Orange	222	84	0	0
162-167	152	Pale Gold	253	171	26	0
157-161	147	Apricot	255	143	13	0
151-156	141	Bright Blue	0	255	87	0
149-150	139	Primary Green	77	255	0	0
147-148	137	Special lavender	219	197	79	0
146	136	Pale Lavender	255	197	61	0
145	135	Deep Golden Amber	255	58	0	0
142-144	132	Medium Blue	0	255	143	0
138-141	128	Bright Pink	255	53	36	0
136-137	126	Mauve	227	41	56	0
134-135	124	Dark Green	84	255	13	0
131-133	121	Leaf Green	206	255	0	0
129-130	119	Dark Blue	0	186	255	0
128	118	Light Blue	74	255	82	0
127	117	Steel Blue	206	255	56	0
126	116	Med Blu Green	206	255	56	0
125	115	Peacock Blue	51	255	51	0
123-124	113	Magenta	255	20	15	0
121-122	111	Dark Pink	255	109	33	0
120	110	Middle Rose	217	130	28	0
119	109	Light Salmon	255	138	31	0
118	108	English Rose	255	148	23	0
117	107	Light Rose	255	141	31	0
115-116	105	Orange	255	122	0	0
114	104	Deep Amber	255	166	0	0
113	103	Straw	230	160	0	69
112	102	Light Amber	237	163	0	0
110-111	100	Spring Yellow	245	202	0	0
100-109	90	Dark yellow green	41	219	0	0
89-99	79	Just Blue	0	194	130	0
78-88	68	Sky Blue	0	255	135	0
68-77	58	Lavender	243	117	133	199
62-67	52	Light Lavender	243	117	39	197
49-61	39	Pink Carnation	255	107	0	130
46-48	36	Medium Pink	255	87	0	107
45	35	Light Pink	255	112	0	141
35-44	25	Sunrise Red	255	83	2	0
32-34	22	Dark Amber	255	65	0	0
31	21	Gold Amber	255	100	0	0
30	20	Medium Amber	255	135	0	0
29	19	Fire	255	56	0	0
27-28	17	Surprise Peach	198	114	9	0
23-26	13	Straw Tint	152	115	9	0
20-22	10	Medium Yellow	156	126	0	0
19	-	Black	0	0	0	0
18	-	White 5000 K	255	137	0	193
17	-	White 3700 K	255	201	25	255
16	-	White 7000 K	216	237	61	255
15	-	Magenta	255	0	255	0
14	-	Yellow	255	255	0	0
13	-	Cyan	0	255	255	0
12	-	Blue	0	0	255	0
11	-	Green	0	255	0	0
10	-	Red	255	0	0	0
0-9	-	Macro color OFF	-	-	-	-

• STOP STROBE



BIT	EFFECT
252 - 255	LED ON
239 - 251	RANDOM FAST STROBE
226 - 238	RANDOM MEDIUM STROBE
213 - 225	RANDOM SLOW STROBE
208 - 212	LED ON
207	FAST PULSATION (25 flash/sec)
108	SLOW PULSATION (0,5 flash/sec)
104 - 107	LED ON
103	FAST STROBE (25 flash/sec)
4	SLOW STROBE (1 flash/sec)
0 - 3	LED OFF

• DIMMER



BIT	EFFECT
255	MAXIMUM BRIGHTNESS
0	NO LIGHT

• DIMMER FINE



BIT	EFFECT
255	UPPER BRIGHTNESS
0	LOWER BRIGHTNESS

• PAN

Operation with option InvertPan \diamond Off

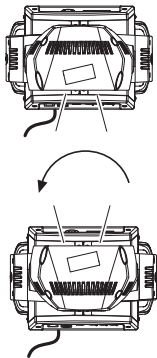

BIT
255
0

0-255 Bit: 2.65 sec (K20)
0-255 Bit: 2.01 sec (K10)
0-255 Bit: 1.41 sec (K5)

Operation with option InvertPan \diamond On

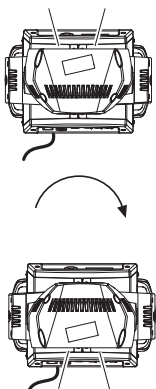

BIT
255
0

0-255 Bit: 2.65 sec (K20)
0-255 Bit: 2.01 sec (K10)
0-255 Bit: 1.41 sec (K5)

• PAN FINE

Operation with option InvertPan \diamond Off

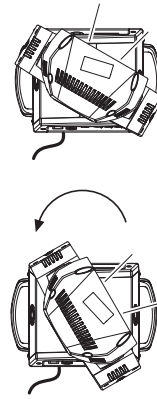

BIT
255
0

Operation with option InvertPan \diamond On

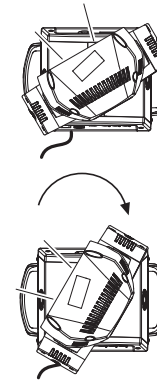

BIT
255
0

• TILT

Operation with option InvertTilt \diamond Off

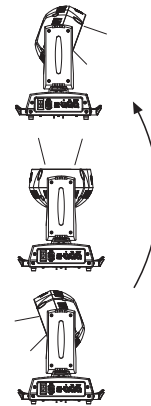

BIT
255
0

0-255 Bit: 1.45 sec (K20)
0-255 Bit: 0.87 sec (K10)
0-255 Bit: 0.80 sec (K5)

Operation with option InvertTilt \diamond On

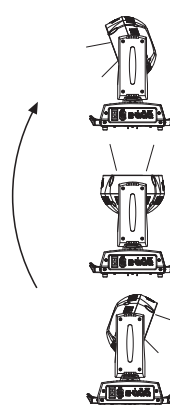

BIT
255
0

0-255 Bit: 1.45 sec (K20)
0-255 Bit: 0.87 sec (K10)
0-255 Bit: 0.80 sec (K5)

• TILT FINE

Operation with option InvertTilt \diamond Off

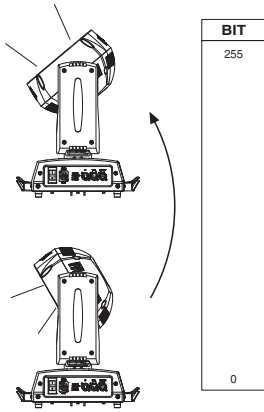

Operation with option InvertTilt \diamond On

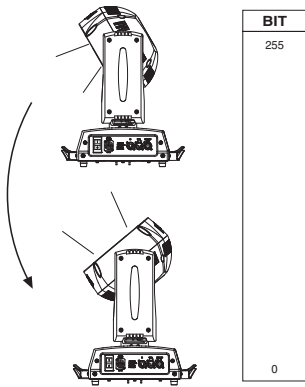

• FUNCTION

BIT	EFFECT
103 – 255	Reserved
98 – 102	Halogen Lamp Simulation, type 5 (2500 W) Linear CTO @ 0
93 – 97	Halogen Lamp Simulation, type 4 (2000 W) Linear CTO @ 0
88 – 92	Halogen Lamp Simulation, type 3 (1200 W) Linear CTO @ 0
83 – 87	Halogen Lamp Simulation, type 2 (1000 W) Linear CTO @ 0
78 – 82	Halogen Lamp Simulation, type 1 (750W) Linear CTO @ 0
73 – 77	Halogen Lamp Simulation OFF (Default)
68 – 72	RGBW Gamma curve 3 – gamma = 2.0
63 – 67	RGBW Gamma curve 2 – gamma = 1.5
58 – 62	RGBW Gamma curve 1 – gamma = 1.0
52 – 57	Dimmer Curve 4
48 – 52	Dimmer Curve 3
43 – 47	Dimmer Curve 2
38 – 42	Dimmer Curve 1
24 – 37	Pan Tilt Normal
12 – 24	Pan Tilt Fast (Default)
0 – 11	Function off – rearmed

The functions are activated passing through the “unused range” and staying 5 seconds in necessary level.

Last selected function still active. Enable setting a new function.

DIMMER CURVE 1 - GAMMA 1 LINEAR

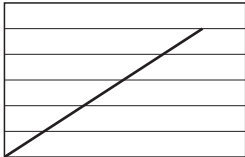

DIMMER CURVE 3 - GAMMA 2,0

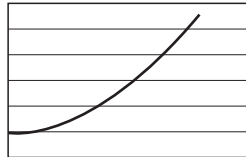

DIMMER CURVE 2 - GAMMA 1,5

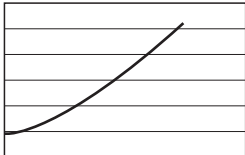

DIMMER CURVE 4 - S

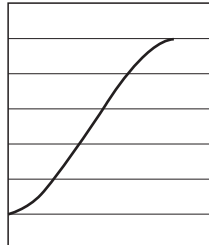

• RESET

BIT	EFFECT
255	COMPLETE RESET
128 127	COMPLETE RESET PAN / TILT RESET
77 76	PAN / TILT RESET ZOOM RESET
26 25	ZOOM RESET
0	UNUSED RANGE

• ZOOM



BIT	EFFECT
255	WIDE BEAM
0	NARROW BEAM

0-255 Bit: 0.68 sec (K20)
0-255 Bit: 0.69 sec (K10)

• RED LED 1 to...
GREEN LED 1 to...
BLUE LED 1 to...
WHITE LED 1 to...



BIT	EFFECT
255	MAXIMUM BRIGHTNESS
0	LED OFF

SHAPE SELECTION - SHAPE SPEED - SHAPE OFFSET

SHAPE SELECTION	SHAPE NAME	On K5	On K10	On K20	DESCRIPTION	Random colors *1	SHAPE SPEED	SHAPE OFFSET
0-7	Macro OFF	Yes	Yes	Yes		N.a.	N.a.	N.a.
8	Ring 1	Yes	Yes	Yes	Static effects. The ring or rings used by the macro are turned-on with the foreground	N.a.	N.a.	N.a.
9	Ring 2	Yes	Yes	Yes				
10	Ring 3	No	Yes	Yes				
11	Ring 4	No	No	Yes				
12	Ring 1 + 2	Yes	Yes	Yes				
13	Ring 1 + 3	No	Yes	Yes				
14	Ring 1 + 4	No	No	Yes				
15	Ring Opening (Closing)	Yes	Yes	Yes		Yes	0-126 = max to min speed, Closing effect 127-128 = STOP 129-255 = min to max speed, Opening effect	
16	Ring Opening (Closing) Filled	Yes	Yes	Yes	Yes			
17	Ring Open/Close (close/open)	Yes	Yes	Yes		Yes	0-126 = max to min speed, Start closed	0-9 → continuous 10-255 → random distribution of flash from 2 to 20 fixtures
18	Ring Open/Close (close/open) Filled	Yes	Yes	Yes		Yes	127-128 = STOP 129-255 = min to max speed, Start opened	
19	Ring with variable radius	Yes	Yes	Yes		N.a.	0-255 = radius:	0-255 → angle offset from 0 to 360°
20	Ring with variable radius, filled.	Yes	Yes	Yes		N.a.	0 = minimum 255 = maximum	N.a.
21	Random pixels distributed on many fixtures	Yes	Yes	Yes		Yes	0-126 = max to min speed, Instant-on + fadeout.	0-255 → select random distribution from 2 up to 20 fixtures
22	Random pixels with variable density and speed	Yes	Yes	Yes		Yes	127-128 = STOP. 129-255 = min to max speed, FadeIn + FadeOut. Fade or snap depending on fade channel.	0-255 → select pixel density
23	Rainbow 1, variable speed.	Yes	Yes	Yes		N.a.	0-126 = max to min speed, c.cw rotation 127-128 = STOP 129-255 = min to max speed, cw rotation	0-255 → angle offset from 0 to 360°
24	Rainbow 2, fixed speed with variable color offset.	Yes	Yes	Yes		N.a.	0-126 = c.cw rotation 127-128 = STOP 129-255 = cw rotation The value 0-126 or 129-255 change the rainbow angle offset (the orange starting angle).	N.a.
25	Fan (3 arms)	Yes	Yes	Yes		N.a.	0-126 = max to min speed, c.cw rotation 127-128 = STOP 129-255 = min to max speed, cw rotation*	0-255 → angle offset from 0 to 360°
26	Bar (2 arms)	Yes	Yes	Yes				
27	Half moon	Yes	Yes	Yes				
28	Triangle	Yes	Yes	Yes				
29	Two rotating bars of different colors	Yes	Yes	Yes				
30	Two rotating arcs of different colors	No	Yes	Yes				
31	Two rotating arcs of different colors and direction	No	Yes	Yes				
32-255	Reserved					N.a.	N.a.	N.a.

*1: Random colors activation with foreground R,G,B,W = 0 bit

Macro Off

DMX channel value: from 0 to 7.

No shape effects activated. Turns off any previously selected shape.

Static Rings

DMX channel value: from 8 to 14.

The ring or rings used by the macro are turned on with the foreground colour (Shape Red+Shape Green+Shape blue+Shape White).

Available combinations: Ring 1 On, Ring 2 On, Ring 3 On (Aleda K10, K20 only), Ring 4 On (Aleda K20 only), Ring 1+2 On, Ring 1+3 On (Aleda K10, K20 only), Ring 1+4 On (Aleda K20 only).

Dynamic Rings

DMX channel

Dynamic Rings

DMX channel value: From 15 to 18.

The rings used by the macro are turned on sequentially, simulating an opening, closing or both.

The Shape Speed channel increases the speed from 126 (min speed) to 0 (max speed) for the closing and closing/opening effects and from 129 (min speed) to 255 (max speed) for the opening and opening/closing effects. With DMX value = 127 or 128 the macro stays still.

The Shape Offset channel defines the macro effect distribution over a number of fixtures (affects also the behavior of a single fixture)

Dmx values from 0 to 9: continuous distribution;

Dmx values from 10 to 255 random distribution of flash from 2 to 20 fixtures.

If foreground colors are all set to 0, the Random-Colors mode is activated.

The color used by the macro changes at every restart.

Rings with variable radius

DMX channel value: 19 - 20.

The Shape Speed channel defines the ring radius: 0 = min, 255 = max.

Random pixels

DMX

Random pixels

DMX channel value: 21 – 22.

Leds are turned on and off randomly.

The Shape Speed channel increases the speed and defines the fade effect for the leds: from 126 (min speed) to 0(max speed) with a Instant-on/ fade-out led effect, and from 129 (min speed) to 255 (max speed)with a fade-in + fade-out led effect. At a DMX value of 127 and 128 the macro stays still.

For macro 21 the Shape Offset channel defines leds random distribution from 0 (2 fixtures) to 255 over a set of fixtures (20 fixtures).

For macro 22 the Shape Offset channel defines pixels density from 0 (min density) to 255 (max density).

If foreground colors are all set to 0 the Random-Colors mode is activated.

The Shape Smoothing channel adjusts the fading effect applied to the macro movement

Rainbows

DMX channel value: 23 – 24 .

It simulates a rainbow effect.

The Shape Speed channel increases the speed and defines the rotation : from 126 (min speed) to 0 (max speed) counter clock wise rotation and from 129 (min speed) to 255 (max speed) clock wise rotation. With DMX value 127 or 128 the macro stays still.

For the macro 24 (Rainbow with fixed speed) the Shape Speed channel also defines angle offset (the orange sector starting angle).

Rotating shapes

DMX channel value: from 25 to 31.

Shapes available: Fan (3 arms), Bar (2 arms), Half Moon, Triangle, Two rotating bars of different colors, Two rotating arcs of different colors, Two rotating arcs of different colors and direction.

The Shape Speed channel increases the speed and defines the rotation : from 126 (min speed) to 0 (max speed) counter clock wise rotation and from 129 (min speed) to 255 (max speed) clock wise rotation. With DMX value 127 or 128 the macro stays still.

The Shape Offset channel defines the angle offset from 0 (0 degree) to 255 (360 degree).

• **SHAPE FADE**

BIT	EFFECT
246-255	Smooth, fading curve with automatic gamma *
245	Smooth, fading curve gamma 2
243	Smooth, fading curve gamma 1,986
244	Smooth, fading curve gamma 1,993
.....	
18	Smooth, fading curve gamma 0,513
17	Smooth, fading curve gamma 0,506
16	Smooth, fading curve gamma 0,5
0-15	Snap

• **SHAPE RGBW
SHAPE DIMMER
BACKGROUND DIMMER**



BIT	EFFECT
255	MAXIMUM BRIGHTNESS
.....	
0	LED OFF

• **SHAPE TRANSITION**

BIT	EFFECT
255	4 sec
.....	
216	3 sec
.....	
171	2 sec
.....	
113	1 sec
.....	
73	0,5 sec
.....	
5	100 ms
0-4	No fade

A.LEDA WASH K10

LED reference number for pixel mapping
TILT: channel 16 @ bit 200

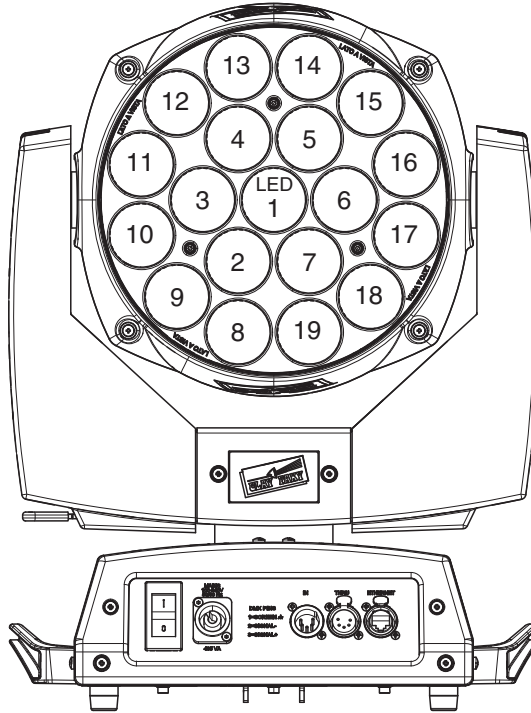

A.LEDA WASH K20

LED reference number for pixel mapping
TILT: channel 16 @ bit 200

