

CLF Conan

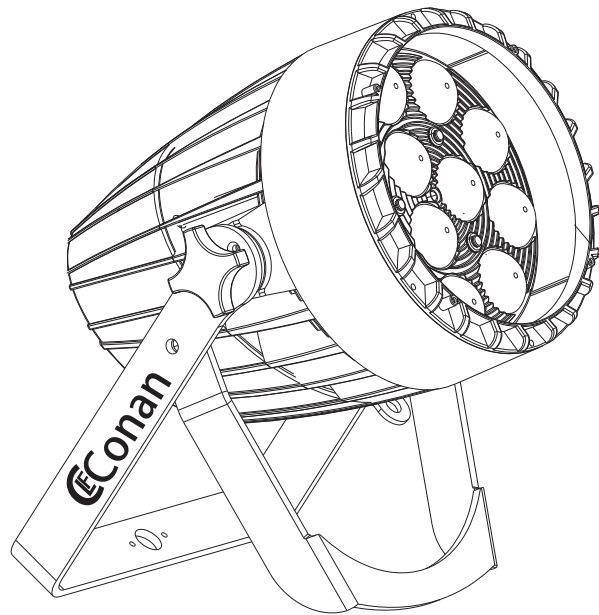

Dimensions

All dimensions are in millimeters

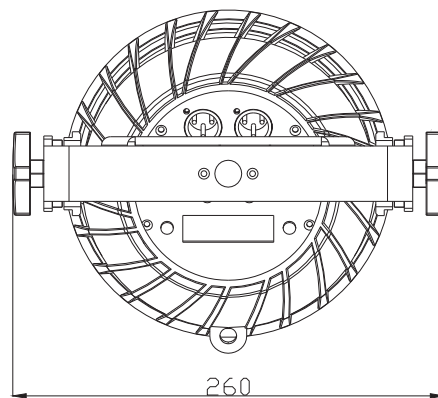
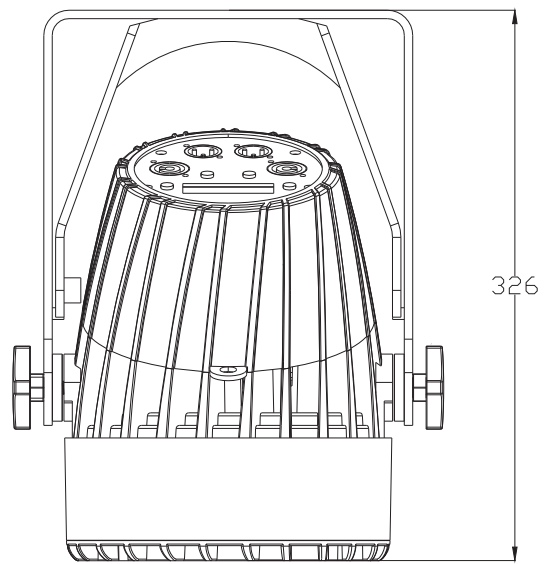
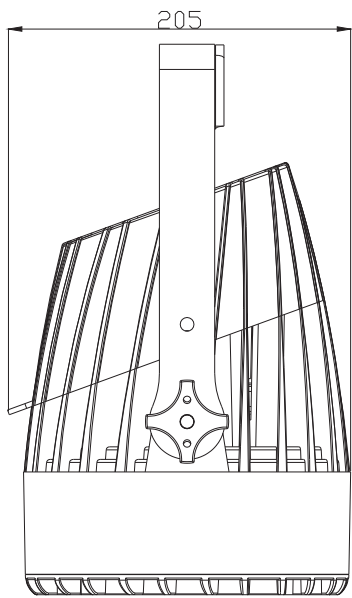

Safety Information



WARNING!

Read the safety precautions in this section before installing, powering, operating or servicing this product

The following symbols are used to identify important safety information on the product and in this manual:



DANGER!
Safety hazard.
Risk of severe injury or death.



DANGER!
Hazardous voltage. Risk of lethal or severe electric shock.



WARNING!
Fire hazard.



WARNING!
LED light emission. Risk of eye injury.



WARNING!
Burn hazard. Hot surface. Do not touch.



WARNING!
Wear protective eyewear.



WARNING!
Refer to user manual.



Warning! Risk Group 3 (high risk) LED product according to EN 62471. Do not look into the beam at a distance of less than 8.3 meters from the front surface of the product. Do not view the light output with optical instruments or any device that may concentrate the beam.

This product is for professional use only. It is not for household use.



This product presents risks of severe injury or death due to fire and burn hazards, electric shock and falls.

Read this manual before installing, powering or servicing the fixture, follow the safety precautions listed below and observe all warnings in this manual and printed on the fixture. If you have questions about how to operate the fixture safely, please contact your supplier



PROTECTION FROM ELECTRIC SHOCK

- Disconnect the fixture from AC power before removing or installing any cover or part and when not in use.
- Always ground (earth) the fixture electrically.
- Use only a source of AC power that complies with local building and electrical codes and has both overload and ground-fault (earth-fault) protection.
- Before using the fixture, check that all power distribution equipment and cables are in perfect condition and rated for the current requirements of all connected devices.
- Power input and throughput cables must be rated 20 A minimum, have three conductors 1.5 mm² (16 AWG) minimum conductor size and an outer cable diameter of 5 - 15 mm . Cables must be hard usage type (SJT or equivalent) and heat-resistant to 90° C minimum.
- Use only PowerCon cable connectors to connect to power input sockets. Use only PowerCon cable connectors to connect to power through put sockets.
- Isolate the fixture from power immediately if the power plug or any seal, cover, cable, or other component is damaged, defective, deformed, wet or showing signs of overheating. Do not reapply power until repairs have been completed.



- Do not expose the fixture to rain or moisture.
- Refer any service operation not described in this manual to a qualified technician.
- Socket outlets used to supply fixture fixtures with power or external power switches must be located near the fixtures and easily accessible so that the fixtures can easily be disconnected from power.

PROTECTION FROM BURNS AND FIRE



- Do not operate the fixture if the ambient temperature (T_a) exceeds 40°C .
- The exterior of the fixture becomes hot during use. Avoid contact by persons and materials. Allow the fixture to cool for at least 10 minutes before handling.



- Keep all combustible materials (e.g. fabric, wood, paper) at least 100 mm away from the head.
- Keep flammable materials well away from the fixture.
- Ensure that there is free and unobstructed airflow around the fixture.
- Do not illuminate surfaces within 200 mm of the fixture.
- Do not attempt to bypass thermostatic switches or fuses.
- If you relay power from one fixture to another using power throughput sockets, do not connect more than ten fixture fixtures in total to each other in an interconnected chain.
- Connect only other fixture fixtures to fixture power throughput sockets. Do not connect any other type of device to these sockets.
- Do not stick filters, masks or other materials onto any optical component.
- Do not modify the fixture in any way not described in this manual

PROTECTION FROM INJURY



- Do not look continuously at LEDs from a distance of less than 8.3 meters from the front surface of the fixture without protective eyewear such as shade 4-5 welding goggles. At less than this distance, the LED emission can cause eye injury or irritation. At distances of 8.3 meters and above, light output is harmless to the naked eye provided that the eye's natural aversion response is not overcome.
- Do not look at LEDs with magnifiers, telescopes, binoculars or similar optical instruments that may concentrate the light output.



- Ensure that persons are not looking at the LEDs from within 8.3 meters when the product lights up suddenly. This can happen when power is applied, when the product receives a DMX signal, or when SERVICE menu items are selected.
- Fasten the fixture securely to a fixed surface or structure when in use. The fixture is not portable when installed.



- Ensure that any supporting structure and/or hardware used can hold at least 10 times the weight of all the devices they support.
- Allow enough clearance around the head to ensure that it cannot collide with an object or another fixture when it moves.
- Check that all external covers and rigging hardware are securely fastened.
- Block access below the work area and work from a stable platform whenever installing, servicing or moving the fixture.
- Do not operate the fixture with missing or damaged covers, shields or any optical component.

Contents

Dimensions	2
Safety Information	3
Fixture overview	6
Introduction	7
Using for the first time	7
AC power	8
Power voltage	8
Power cables and power plug	8
Relaying power to other devices	9
Data link	9
Connecting the data link	9
Tips for reliable data transmission	9
Physical installation	10
Fastening the fixture to a flat surface.	10
Setup	11
Control panel and menu navigation	11
DMX address setting	11
WDMX control	11
Control mode	12
Restoring factory default settings	12
Operation and effects	13
Effects	13
DMX protocol	14
Standard mode.	14
Manual mode	16
Onboard control menus	17
CALIBRATION	18
Specifications	19

Fixture overview

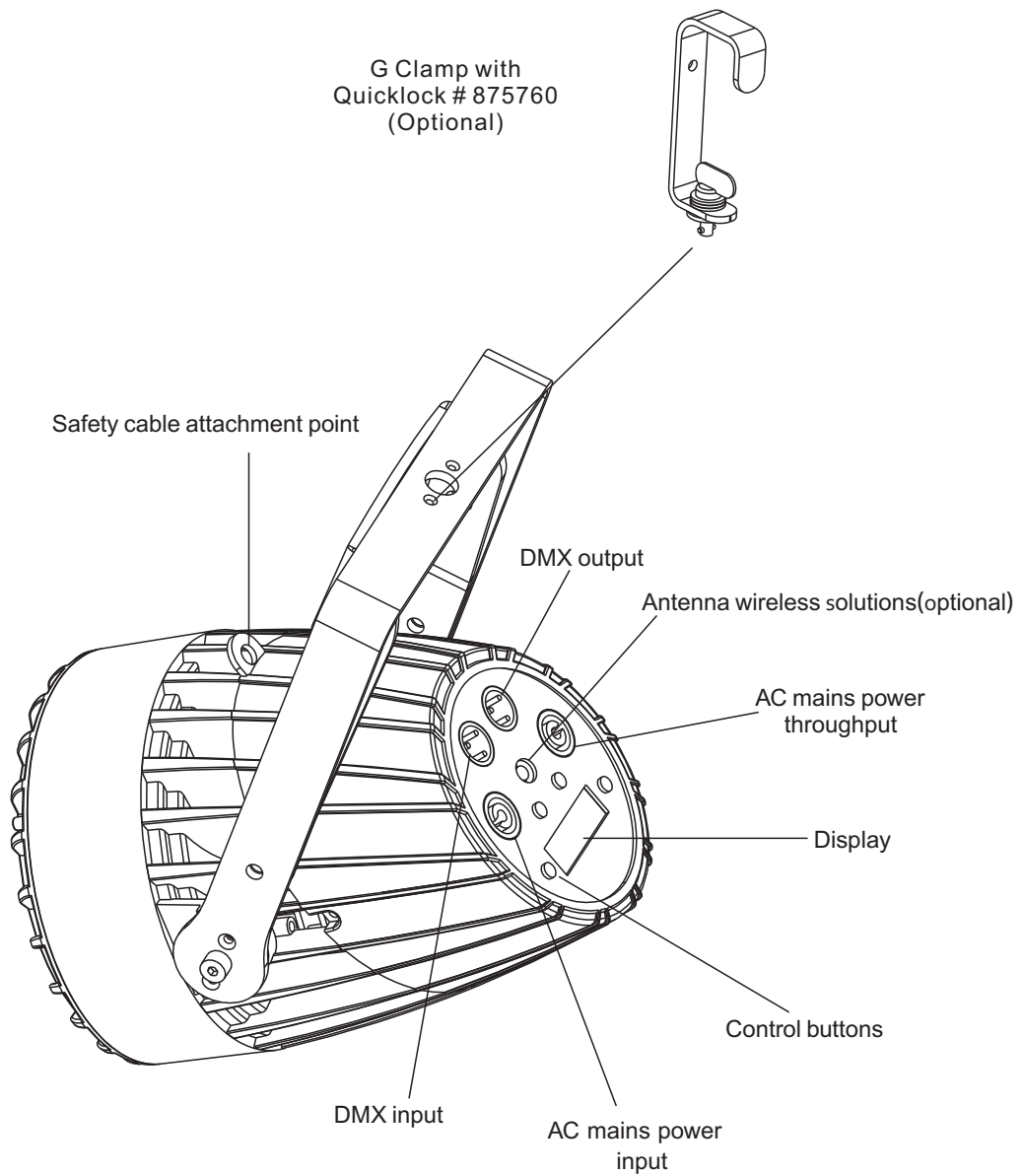

Note: head fan grill in production models is rotated 90° compared to this illustration.

Introduction

- This compact LED-based Parcan features:
- Beam RGBW color control with color temperature control
- 'Color wheel' color snap Beam
- Onboard control panel and backlit LCD graphic display
- Motorized zoom
- Smooth electronic dimming
- Electronic shutter with strobe and pulse effects
- Calibrated and raw modes
- Osram Ostar high-power emitters
- DMX control

Using for the first time



Warning! Read “Safety Information” on page 3 before installing, powering, operating or servicing the fixture. Before applying power to the fixture:.

- Carefully review “Safety Information” starting on page 3.
- Check that the local AC mains power source is within the fixture’s power voltage and frequency ranges.
- See “Power cables and power plug” on page 8. Install a PowerCon power input connector on a suitable power cable. If drawing power from a mains power outlet, install a suitable power plug on the power cable.

AC power



Warning! Read “Safety Information” starting on page 3 before connecting the fixtures to AC mains power.

Warning! For protection from electric shock, the fixture must be grounded (earthed). The power distribution circuit must be equipped with a fuse or circuit breaker and ground-fault (earth-fault) protection.



Warning! Socket outlets or external power switches used to supply the fixture with power must be located near the fixture and easily accessible so that the fixtures can easily be disconnected from power.

Important! Do not insert or remove live PowerCon connectors to apply or cut power, as this may cause arcing at the terminals that will damage the connectors.

Important! Do not use an external dimming system to supply power to the fixture, as this may cause damage to the fixture that is not covered by the product warranty.

The fixture can be hard-wired to a building electrical installation if you want to install it permanently, or a power plug that is suitable for the local power outlets can be installed on the power cable.

Power voltage



Warning! Check that the voltage range specified on the fixture’s serial number label matches the local AC mains power voltage before applying power to the fixture.

The fixtures accept AC mains power at 100-240 V nominal, 50/60 Hz. Do not apply AC mains power to the fixture at any other voltage than that specified on the fixture’s serial number label.

Power cables and power plug

Power input and throughput cables must be rated 20 A minimum, have three conductors 1.5 mm² (16 AWG) minimum conductor size and an outer cable diameter of 5 - 15 mm. Cables must be hard usage type (SJT or equivalent) and heat-resistant to 90° C minimum. In the EU the cable must be HAR approved or equivalent.

If you install a power plug on the power cable, install a grounding-type (earthed) plug that is rated 20 A minimum. Follow the plug manufacturer’s instructions. Table 1 shows standard wire color-coding schemes and some possible pin identification schemes; if pins are not clearly identified, or if you have any doubts



Wire Color (EU models)	Wire Color (US models)	Conductor	Symbol	Screw (US)
brown	black	live	L	yellow or brass
blue	white	neutral	N	silver
yellow/green	green	ground (earth)	 or 	green

Table 1: Wire color-coding and power connections

Relaying power to other devices



Warning! Do not connect more than ten fixture fixtures in total to AC mains power in one interconnected chain

Power can be relayed to another device via the light-grey PowerCon throughput socket that accepts a light-grey PowerCon cable connector. Note that blue input and light-grey throughput connectors have different designs: one type cannot be connected to the other.

If you link fixtures in a chain so that they all draw AC mains power via the first fixture, certain points must be respected:

- A hard usage, three-conductor, 16 AWG or 1.5 mm² cable with SJT or equivalent cable jacket must be used to connect the first fixture to AC mains power and to interconnect all the fixtures in the chain up to a maximum of seven fixtures in total.
- Light-grey PowerCon connectors must be used to draw AC mains power from the fixtures' power throughput sockets and blue PowerCon connectors must be used to supply power at the fixture's power input sockets.
- No matter what the AC mains power voltage is, do not connect more than ten fixture fixtures in total (i.e. including the first fixture) to AC mains power in one interconnected daisy chain using power input and throughput connectors.

Data link

A DMX 512 data link is required in order to control a fixture via DMX.

The fixture has 3-pin XLR connectors for DMX data input and output. The pin-out on all connectors is pin 1 = shield, pin 2 = cold (-), and pin 3 = hot (+).

Or the fixture has 5-pin XLR connectors for DMX data input and output. The pin-out on all connectors is pin 1 = shield, pin 2 = cold (-), and pin 3 = hot (+). Pins 4 and 5 in the 5-pin XLR connectors are not used

Connecting the data link

To add more fixtures or groups of fixtures when the above limit is reached, add a DMX universe and another daisy-chained link.

Use shielded twisted-pair cable designed for RS-485 devices: standard microphone cable cannot transmit control data reliably over long runs. 24 AWG cable is suitable for runs up to 300 meters. Heavier gauge cable and/or an amplifier is recommended for longer runs.

Tips for reliable data transmission

To connect the fixture to data:

1. Connect the DMX data output from the controller to the closest fixture's male 3-pin XLR DMX input connector.
2. Connect the DMX output of the fixture closest to the controller to the DMX input of the next fixture and continue connecting fixtures output to input.

Physical installation



Warning! The fixture must be either fastened to a flat surface such as a stage or wall, or clamped to a truss or similar structure in any orientation using a rigging clamp. Do not apply power to the fixture if it is standing freely or the fixture can be moved.

Warning! If the fixture can cause injury or damage if it falls, attach an approved safety cable to one of the safety cable attachment points on the base (see “Fixture overview” on page 6).

Check that all surfaces to be illuminated are minimum 200 mm. from the fixture, that combustible materials (wood, fabric, paper, etc.) are minimum 100 mm. from the head, that there is free airflow around the fixture and that there are no flammable materials nearby.

Make sure that it is impossible for the moving head to collide with another fixture or other object...

Fastening the fixture to a flat surface

The fixture can be fastened to a fixed flat surface that is oriented at any angle. Check that the surface can support at least 10 times the weight of all fixtures and equipment to be installed on it.



Warning! The supporting surface must be hard and flat or air vents in the base may be blocked, which will cause overheating. Fasten the fixture securely. Do not stand it on a surface or leave it where it can be moved or can fall over. Attach a securely anchored safety cable to the safety cable attachment point (see “Fixture overview” on page 6) if the fixture is to be installed in any location where it may fall and cause injury or damage if the primary attachment fails.

3. Block access under the work area. Working from a stable platform, hang the fixture on the truss with the arrow on the base towards the area to be illuminated. Tighten the rigging clamp.
4. Secure the fixture against clamp failure with a secondary attachment such as an approved safety cable that is rated for the weight of the fixture using one of the attachment points at the edges of the base (see “Fixture overview” on page 6). Do not use any other part of the fixture as a safety cable attachment point.
5. Check that the head will not collide with other fixtures or objects.

Setup



Warning! Read “Safety Information” on page 3 before installing, powering, operating or servicing the fixture.

Control panel and menu navigation

The onboard control panel and backlit graphic display are used to set the fixture's DMX address, configure individual fixture settings (personality), read out data and execute service utilities. See “Onboard control menus” on page 17 for a complete list of menus and commands.

Using the control buttons

- To enter a menu, select a function or apply a selection, press ► (Enter).
- Press ▲ (Up) and ▼ (Down) to scroll within a menu or adjust values.
- To escape a function or move back one level in the menu structure, press ◀ (MODE).
- Holding down the "UP" or "DOWN" button for more than 3 seconds, the MENU display rotated 180°

DMX address setting

The DMX address, also known as the start channel, is the first channel used to receive instructions from the controller. For independent control, each fixture must be assigned its own control channels.



The DMX address is configured using the DMX ADDRESS menu in the control panel.

- In order to facilitate for inspection the signal, If the display to flicker when it's not receiving any signalNotes

WDMX control

Press the button “UP” to switch off Wireless DMX or disconnect with all connected Transmitters.

Press the button “DOWN” to set the unit in the "ready to connect with all not connected transmitters" mode. If you press the mode button on the Wireless solution transmitter all the ready to connect units will be connected.

If the unit is successfully connected in the home display the sign “”. Appears. If the unit is not connected to a transmitter or switched off no “”. sign is visible

CONTROL MODE

Standard and **Manual** modes

DMX control mode is selected in the **CONTROL MODE** menu. The fixture has two DMX control modes:

- **Standard** (Standard mode – uses 10 DMX channels)
- **Manual mode** (Extended mode – uses 4 DMX channels+manual zoom)

Dimming

DIMMER CURVE provides four dimming options (see picture below):

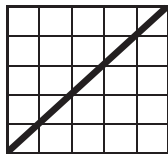

Optically linear

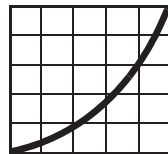

Square law

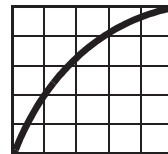

Inverse square law

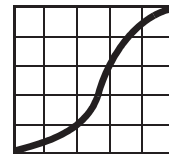

S-curve

- **LINEAR** – the increase in light intensity appears to be linear as DMX value is increased.
- **SQUARE LAW** – light intensity control is finer at low levels and coarser at high levels.
- **INVERSE SQUARE LAW** – light intensity control is coarser at low levels and finer at high levels.
- **S-CURVE** – light intensity control is finer at low levels and high levels and coarser at medium levels. Whichever **DIMMER CURVE** option you select, you can choose between **NORMAL** or **SMOOTH** dimming settings:
- **NORMAL** is the default setting. It gives a virtually instantaneous reaction when you dim from one intensity to another, but dimming slowly from one intensity to another may appear slightly uneven.
- The **SMOOTH** setting gives smoother dimming during slow changes in intensity, but it limits the speed of dimming changes slightly. This makes it ideal for slow, smooth dimming, but a short time-lag may be noticeable if you try to dim quickly from one intensity to another.

Restoring factory default settings

The fixture factory default settings can be restored by applying a **FACTORY SETTING** → **LOAD** command.

Operation and effects



Warning! Read “*Safety Information*” starting on page 3 before installing, powering, operating or servicing the fixture.

This section describes only DMX control features that require particular explanation. See “DMX protocols” on page 14 for a full list of the DMX channels and values required to control the different effects.

Effects

Shutter effect

The electronic ‘shutter’ effect available for the Beam provides instant open and blackout, variable speed regular and random strobe and opening/closing pulse effects as well as burst and sine wave effects.

Dimming

Beam and intensity can be adjusted 0 - 100% using electronic dimming. See the available dimming curve options in “Dimming” on page 12

Zoom

The Beam can be zoomed from 58° to maximum (narrow) 11° one-tenth peak angles.

Controlling color

Color wheel effects

The electronic ‘color wheel’ effects available for the Beam give the convenience and feel of a mechanical color wheel and let you snap between 33 different full LEE-referenced colors. You can also scroll continuously forwards or backwards through the colors or display random colors at variable speed.

Color wheel priority

The color wheel effect channels for the Beam have priority and override any color set on the Beam RGBW channels. To use the RGBW and RGB channels, you must set the color wheel effect channel for Beam to a DMX value from 000 – 009. If you set either color wheel channel to a DMX value above 009, the color wheel effect overrides RGBW or RGB control.

CTC (Color Temperature Control)

CTC is available for the Beam on the CTC channel 10. Setting this channel to DMX value 20 or above allows you to adjust the Beam’s overall color temperature, i. e. the color that has been set using the color wheel channel or the RGBW channels. Note that the more saturated the color, the less it will be affected by adjustments in color temperature. The biggest CTC variation is available when displaying white.

Overall color temperature can be varied from 10 000–2500K. The default color temperature is 5600K.

DMX protocols

Standard mode

Standard	DMX Value	Percent	Function	
1	0 - 19	0 - 7	Electronic shutter effect	
	20 - 24	8 - 9	Shutter closed	
	25 - 64	10 - 25	Shutter open	
	65 - 69	26 - 27	Strobe 1 (fast → slow)	
	70 - 84	28 - 33	Shutter open	
	85 - 89	34 - 35	Strobe 2: opening pulse (fast → slow)	
	90 - 104	36 - 41	Shutter open	
	105 - 109	42 - 43	Strobe 3: closing pulse (fast → slow)	
	110 - 124	44 - 49	Shutter open	
	125 - 129	50 - 51	Strobe 4: random strobe (fast → slow)	
	130 - 144	52 - 57	Shutter open	
	145 - 149	58 - 59	Strobe 5: random opening pulse (fast → slow)	
	150 - 164	60 - 65	Shutter open	
	165 - 169	66 - 67	Strobe 6: random closing pulse (fast → slow)	
	170 - 184	68 - 73	Shutter open	
	185 - 189	74 - 75	Strobe 7: burst pulse (fast → slow)	
	190 - 204	76 - 81	Shutter open	
	205 - 209	82 - 83	Strobe 8: random burst pulse (fast → slow)	
	210 - 224	84 - 89	Shutter open	
	225 - 229	90 - 91	Strobe 9: sine wave (fast → slow)	
230 - 244	92 - 97	Shutter open		
245 - 255	98 - 100	Strobe 10: burst (fast → slow)		
2	0 - 255	0 - 100	Shutter open	
2	0 - 255	0 - 100	Beam Dimmer	
			0 → 100% intensity	
3	0 - 255	0 - 100	Zoom	
			Wide → narrow	
4	0 - 9	0 - 3	Fixture control settings	
	10 - 14	4 - 5	No function	
	15 - 59	6 - 13	Reset entire fixture ¹	
	60 - 64	14 - 23	No function	
	65 - 69	24 - 25	Fan mode FULL ²	
	70 - 74	26 - 27	No function	
	75 - 89	28 - 33	Fan mode REGULATED ²	
	90 - 94	34 - 35	No function	
	95 - 99	36 - 37	Calibrated color output mode COLOR CALIB = ON ³	
	100 - 104	38 - 40	No function	
	105 - 109	41 - 42	Raw color output mode COLOR CALIB = OFF ³	
	110 - 114	43 - 44	No function	
	115 - 119	45 - 46	Fast dimming, speed of changes unrestricted ²	
	120 - 124	47 - 48	No function	
	125 - 239	49 - 93	Smooth dimming, speed of changes restricted slightly ²	
	240 - 244	94 - 95	No function	
	245 - 249	96 - 97	DMX Manual calibration mode ⁴	
	250 - 255	98 - 100	No function	
				Illuminate display

¹ If DMX Reset is disabled in the menu, a reset command can only be executed if channel 2 is set to 232 and channel 1 is set to zero. These values need to be held for 5 seconds before feature is activated. Values must be "snapped to" to function.

² Menu override: setting unaffected by power off/on.

³ Value must be held for 3 seconds to activate. Setting unaffected by power off/on.

⁴ Please refer the page of 18. (calibrate by DMX control) Value must be held for 3 seconds to activate.

Standard	DMX Value	Percent	Function
5	0 - 9	0 - 1	Beam Color wheel effect No function. RGBW color mixing enabled
	10 - 174	2 - 67	Color wheel effect
	175 - 179	68 - 69	Open
	180 - 201	70 - 78	Color wheel rotation effect Clockwise, fast → slow
	202 - 207	79 - 80	Stop (this will stop wherever the color is at the time)
	208 - 229	81 - 89	Counter-clockwise, slow → fast
	230 - 234	90 - 91	Open
	235 - 239	92 - 93	Random color Fast
	240 - 244	94 - 95	Medium
	245 - 249	96 - 97	Slow
250 - 255	98 - 100	Open	
6	0-255	0-100	Beam Red Red 0 → 100%
7	0-255	0-100	Beam Green Green 0 → 100%
8	0-255	0-100	Beam Blue Blue 0 → 100%
9	0-100	0-100	Beam white white 0 → 100%
10	0-19 20-255	0-07 8-100	Beam CCT No Function CTC 10 000K → 2 500K

Note: DMX values labeled "No function" will have no effect - the last functional value will be used.

Manual mode

Manual	DMX Value	Percent	Function
1	0 - 255	0-100	RED(0-255)
2	0 - 255	0-100	GREEN(0-255)
3	0 - 255	0-100	BLUE(0-255)
4	0 - 255	0-100	WHITE(0-255)
Manual ZOOM	0 - 255	0-100	Wide → narrow

Onboard control menus

Menu	Item	Options	Notes (Default settings in bold print)
DMX ADDRESS		1-XXX	Set DMX start address
CONTROL MODE	Standard mode		10 DMX channels: Control of beam
	Manual mode		4 DMX channels: RGBW+manual zoom
STATIC COLOR	DIMMER	0~255	0~100%
	RED	0~255	0~100%
	GREEN	0~255	0~100%
	BLUE	0~255	0~100%
	WHITE	0~255	0~100%
	ZOOM	0~20	Wide → narrow
	STROBE	0~255	(0~20Hz)Select strobe frequency
PERSONALITY	FANS	REGULATED	Cooling fan speed thermostatically regulated
		FULL	Max. cooling fan speed
	DIMMER MODE	LINEAR	Linear dimming curve
		SQUARE LAW	Square law dimming curve
		INV SQUARE LAW	Inverse square law dimming curve
		S-CURVE	S-curve dimming curve
	DIMMER SPEED	NORMAL	Fast dimming with unrestricted speed
		SMOOTH	Smooth dimming with restricted speed
	DMX RESET	OFF	Disable reset via DMX
		ON	Enable reset via DMX
	DISPLAY	ON	Display is always on
		30S	Display switches off and goes into Sleep mode if the controls have not been pressed for 30 seconds
	WDMX	CONNECT	Connect to the WMDX
		NO CONNECT	Disconnect and exit the WMDX
CALIBRATION	NO CALIBRATION	Color calibration mode off. the RGBW value is the original one.	
	MANUAL	Manual calibration mode, RGBW to white is custom calibration	
	FACTORY	Factory calibration mode, RGBW to white is Factory calibration	
AUTO	AUTO(1-10)		10 Auto programs available
	CUSTOM		Choose custom programs
	TEST ALL		Test LEDs, zoom and display
EDIT	1.Scene	0~255	Select the scene step
	2.BEAM-red	0~255	0~100%
	3.BEAM-green	0~255	0~100%
	4.BEAM-blue	0~255	0~100%
	5.BEAM-white	0~255	0~100%
	6.BEAM-strobe	0~20	(0~20Hz)Select strobe frequency
	7.fade	0~255	transition time of last step to current step
	8.time	0~6.375 S	(0~6.375 S) step time
	9.ZOOM	0~255	Wide → narrow
	10.use	ON/OFF	Enable or Disable scene
INFO	Software type	V2.11	CPU firmware version
	Usage time	TOTAL	XXXX
		RESET	Reset OK
	Temperature	XXX°C	LEDs current temperature
FACTORY SET	LOAD		Return all settings to factory defaults

CALIBRATION

Three mode of color calibration

1, NO CALIBRATION

Color calibration mode off. the RGBW value is the original one.

2,MANUAL

Manual calibration mode, RGBW to white is custom calibration.

Manual calibration can calibrate by control panel and DMX channel.

calibrate by control panel

Press "MODE,ENTER,UP ,DOWN "four button to enter the calibration mode

Menu	Item	Options	Notes (Default settings in bold print)
SETTING MENU	MANUAL CALIBRATION	BEAM-red	000-255
		BEAM-green	000-255
		BEAM-blue	000-255
		BEAM-white	000-255
	Want to quit?	YES/NO	

calibrate by DMX control

channel 4 is set to 245-249 to enter dmx controller calibration

channel	DMX Value	Percent	Function
1	0 - 255	0-100	No function
2	0 - 255	0-100	No function
3	0 - 255	0-100	No function
4	0 - 229	0-100	No function
	230 - 234	0-89	come back to DMX mode ⁵
	240-244	90-95	No function
	245-249	96-97	turn on manual calibration mode by dmx control ⁵
	250-255	98-10	illuminate display
⁵ Value must be held for 3 seconds to activate.			
5	0 - 254	0-99	No function
	255	100	Save Correction, Value must be held for 3 seconds to activate.
6	0 - 255	0-100	RED(0-255)
7	0 - 255	0-100	GREEN(0-255)
8	0 - 255	0-100	BLUE(0-255)
9	0 - 255	0-100	WHITE(0-255)

3,FACTORY calibration mode

change tekst to: Fixture is calibrated in the factory. (done after production date june 2015)

Specifications

Physical

Length260 mm
Width205 mm
Height326 mm
Weight	5.5 kg without accessories

Dynamic Effects

color mixing	RGBW
color temperature control	CTO, variable 10 000 - 2500 K
electronic 'color wheel' effect	21 LEE-referenced colors plus white, variable-speed color-wheel rotation effect and random color
shutter effects	Electronic, with regular and random pulse, burst and strobe effects
Electronic dimming	four dimming curve options
Zoom	11° - 58° (one-tenth peak angle)

Optics

Light source	Osram Ostar high-power long-life emitters
------------------------	---

Control and Programming

ControlDMX
DMX channels	4/10
Setting and addressing	Control panel with backlit graphic display
Protocol	USITT DMX512-A

Construction

Color	Black
Housing	High strength die-casting aluminum
Protection rating.IP 20

Installation

OrientationAny
Minimum distance to combustible materials	100 mm. from fixture
Minimum distance to illuminated surfaces	200 mm. from fixture
LocationIndoor use only, must be fastened to structure or surface

Connections

AC power inputPowerCon input socket (blue)
AC power throughput.PowerCon output socket (grey)
DMX data in/out3/5-pin locking XLR

Electrical

AC power 100-240 V nominal, 50/60 Hz
 Maximum total power consumption 140 W
 Power supply unit Auto-ranging electronic switch mode
 Power consumption, all effects static, zero light output <15 W

Thermal

Cooling Forced air (temperature-regulated, low noise, user-definable levels)
 Maximum ambient temperature (Ta max.) 40° C
 Minimum ambient temperature (Ta min.) 5° C
 Total heat dissipation (calculated, +/- 10%) 820 BTU/hr.

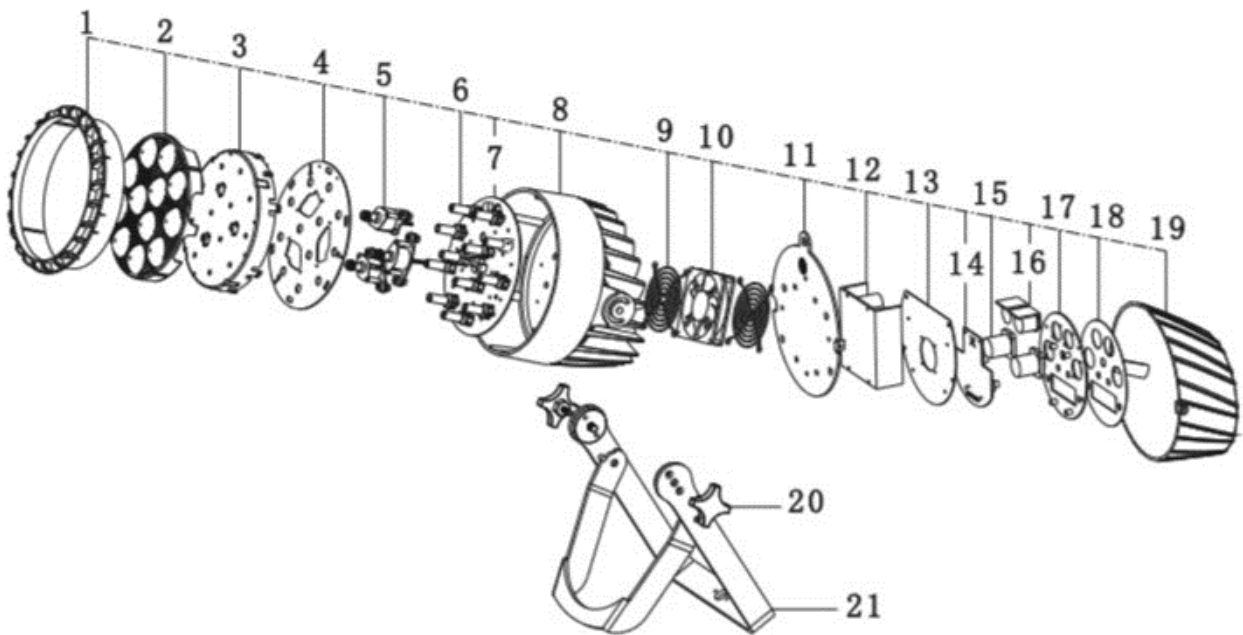

1	CLF Front cover ring Conan	CLF-06-122
2	CLF Lens kit Conan	CLF-06-119
3	CLF Diffuser plate holder Conan	CLF-06-109
4	CLF LED board 3 in 1 Conan	CLF-06-112
5	CLF Zoom motor Conan	CLF-06-118
6	CLF Light guiding tube Conan	CLF-06-108
7	CLF LED board 4 in 1 Conan	CLF-06-111
8	CLF Front case body Conan	CLF-06-107
9	CLF Fan guard Conan	CLF-06-106
10	CLF Fan Conan	CLF-06-117
11	CLF Fan support plate Conan	CLF-06-105
12	CLF Power supply Conan	CLF-06-115
13	CLF Power supply support plate Conan	CLF-06-104
14	CLF Display board Conan	CLF-06-114
15	CLF Powercon input socket Conan	CLF-03-007
16	CLF Xlr5 board Conan	CLF-06-113
17	CLF Display support plate Conan	CLF-06-103
18	CLF Display sticker Conan	CLF-06-123
19	CLF Back case body Conan	CLF-06-102
20	CLF Knob bracket Conan	CLF-06-116
21	CLF Bracket Conan	CLF-06-101